



# VetVision DC X-Ray System



## Installation and Service Manual

REF. KIT #30-A2139

00-02-1606 Rev F

**REV. F**

**ECN: P2523**

**Attention:**

The equipment must only be installed and operated in accordance with the safety procedures and operating instructions given in this manual and in the User Manual for the purposes and applications for which it was designed. Modifications and/or additions to the equipment may only be carried out by Progeny, A Midmark Company or by third parties expressly authorized by Progeny Dental to do so. Such changes must comply with legal requirements as well as with the generally accepted technical rules. It is the responsibility of the user to ensure that existing legal regulations regarding installation of the equipment with respect to the building are observed.

**X-RAY PROTECTION:**

X-ray equipment may cause injury if used improperly.

**The instructions contained in this manual must be read and followed when operating the VetVision DC. Your Progeny Dental dealer will assist you in placing the VetVision DC in operation.**

The VetVision DC X-Ray System provides a high degree of protection from unnecessary x-radiation. However, no practical design can provide complete protection nor prevent operators from exposing themselves or others to unnecessary radiation.



**More Than Imaging. Excellence.**

**Midmark Corporation**

675 Heathrow Drive  
Lincolnshire, Illinois 60069 U.S.A.  
Phone: (888) 924-3800 Fax: (847) 415-9810  
[WWW.progenydental.com](http://WWW.progenydental.com)



# VetVision DC X-Ray System

## **Installation and Service Manual**

00-02-1606 REV. F

**ECN P2523**

### **Midmark Corporation**

675 Heathrow Dr.  
Lincolnshire, Illinois 60069 U.S.A.  
Phone: (888) 924-3800 Fax: (847) 415-9801  
[WWW.progeny dental.com](http://WWW.progeny dental.com)

© Progeny Dental 2006, U.S. Patents D470237, D469182, D470589, 6,837,468, and 6,664,853

---

## Table of Contents

General Information.....	1
Product Description.....	1
Cautions.....	2
Reach and Coverage.....	3
Environmental Factors.....	8
Support Requirements.....	8
Electrical Requirements.....	9
Compliance with Applicable Standards.....	9
Certified Components.....	9
EC Declaration of Conformity.....	10
Authorized Representatives.....	11
Safety.....	11
Explanation of Symbols on Technical Labels.....	12
Obtaining Technical Support.....	12
Installation Options.....	13
Mounting Configurations.....	13
Operator Panel Locations.....	18
Installation Procedures.....	19
Preparing to Install the VetVision DC.....	19
Installing the Control Unit on a Single Wood Stud Wall.....	21
Installing the Control Unit on a Dual Wood Stud Wall.....	26
Installing the Control Unit on a Metal Stud Wall.....	28
Installing the Horizontal Arm and Brake Assembly.....	30
Installing the Articulating Arm and Tubehead Assembly.....	32
Connecting the Cables.....	34
Electrical Verification.....	37
Mechanical Adjustments.....	40
Installing the Control Unit Front Cover and the Operator Panel.....	41
Installing Plastic Covers.....	45
VetVision DC Operator Panel.....	46
Checking System Functions.....	47
System Function Checklist.....	48
Tube Seasoning Procedure.....	49
Refer to Page 62 for the Calibration procedure.....	49
Optional Installation Procedures.....	50
Installing the Coil-cord Hand Switch Option (30-A2040).....	50
Installing the Progeny Remote Exposure Station (30-A2044).....	52
Installing the 12 Inch Cone (30-A2033).....	56
System Configuration.....	57
System Configuration Mode.....	57
Adjusting the Display.....	58
Changing Pre-programmed Exposure Settings.....	59
Showing Current System Configuration.....	60
Changing the Cone Size.....	61
Diagnostic Mode.....	62

---

Calibration .....	63
Automated Calibration Procedure .....	63
Troubleshooting .....	66
Electrical Performance Issues .....	66
Obtaining Technical Support .....	85
Maintenance.....	86
VetVision DC Tubehead Removal Instructions.....	86
Mechanical Adjustments .....	90
Pre-programmed Exposure Times .....	96
Replacement Parts.....	97
Arm and Tubehead .....	97
Horizontal Arm .....	98
Mounting Plates .....	99
Operator Panel.....	100
Control Unit.....	101
Hand Switch.....	102
Specifications .....	103
VetVision DC X-Ray System .....	103
Appendix A.....	106
Assembly Instructions for VetVision DC Mobile Unit.....	106
Appendix B.....	118
Electronics Block Diagram .....	118

## General Information

### Product Description

	<p>The VetVision DC X-Ray System is a state-of-the-art, high-frequency intra-oral x-ray machine to be used for veterinary purposes only. The VetVision DC consists of five components, as shown in the Control Unit, the Tubehead, the Articulating Arm, the Horizontal Arm, the Cone, and the Remote Control option.</p>
<b>Control Unit</b>	<p>The Control Unit provides for the input power connection and control of the Tubehead and Operator Panel. It provides automatic line voltage compensation, kVp control, and exposure time control. The Control Unit consists of the mounting base and Operator Panel.</p>
<b>Tubehead</b>	<p>The Tubehead contains the x-ray tube, high voltage circuit, and Cone. The Tubehead is shipped already assembled to the Articulating Arm.</p> <p><b>Note:</b> There is a small hole in the plastic handle covering the back of the Tubehead. Under no circumstances should this hole be blocked as it provides an air vent to allow the Tubehead oil to expand and contract as the unit is operated.</p>
<b>Articulating Arm</b>	<p>The Articulating Arm provides the articulation support for the Tubehead and the reach and coverage of the Tubehead to the patient. The Articulating Arm allows smooth movement for precise positioning and does not drift or vibrate when left in position.</p>
<b>Horizontal Arm</b>	<p>The Horizontal Arm helps provide the necessary reach for the VetVision DC. The Horizontal Arm pivots smoothly around a shaft inserted in the top of the Control Unit. The Horizontal Arm contains an access cover to connect the cable from the Horizontal Arm to the Control Unit. The Horizontal Arm is available in three lengths, providing reaches of 56, 66, and 76 inches.</p>
<b>Cone</b>	<p>The Cone establishes the distance from the x-ray tube to the patient's skin. It provides positioning assistance and collimates the x-ray beam to within a defined circle at its end. The VetVision DC is shipped with the standard 8 inch Cone attached to the Tubehead. A 12 inch Cone (30-A2033) can be ordered as an option.</p>
<b>Remote Control</b>	<p>An optional component, the remote control switch is used to make exposures in addition to or replacing the use of the exposure button.</p>
<b>Mobile Unit</b>	<p>An optional device, the mobile unit supports pre-programmed technique selections and x-ray acquisition. See Appendix A for the installation instructions for the mobile unit.</p>
<b>Installation and Service</b>	<p>The VetVision DC X-Ray System should only be installed and serviced by approved Progeny dealer personnel. Contact Progeny at (888) 924-3800 if you need assistance locating an approved dealer.</p>

## CAUTIONS

When using lag screws as the method of attachment, it is imperative to consider the full scope of the task. Several factors must be considered for safe, permanent installations. Some of the key issues are:

- Lumber commonly used in construction projects can be different from location to location.
- The grade, age, position, and overall condition can vary greatly.
- The attachment stud may have additional, hidden loads.
- The location of the pilot hole with respect to the center of the stud will affect the load bearing ability.
- The size of the pilot hole required for the lag screw will be different based on the grade, age and condition of the lumber.
- Never over-tighten the lag screw as this will weaken the mechanical connection.
- Lumber with splits or cracks should not be used for attachment.
- **Plywood, particle board, or similar construction materials, should not be used for attachment.**
- Consider lumber dryness or moisture when attaching to exterior framing studs.
- Progeny mechanical designs will exert up to 850 pounds (386 kilograms) of loading on the supporting structure.
- Progeny provides fasteners for average installations. Based on specific installation conditions, it may be necessary to choose an alternate fastener or fastening methods.
- Seek the advice of a professional structural engineer to clarify any issues before the installation.
- Inspect the attachment method 30 days after the installation and, every 6 months thereafter.
- Lag screws are not intended to be used as an attachment method for metal supports such as those found in center island pass-through cabinets. Progeny provides machine screws, large flat washers and nylock nuts to use when fastening the system to metal supports.

### Your responsibilities as an installer and service engineer

***Verification of machine performance after installation*** must be performed according to the guidelines identified in the “System Function Checklist” which may be found in the User Manual or, the Installation and Service Manual.

***Verification of machine performance after maintenance or repair*** must be performed according to the guidelines identified in the “System Function Checklist” and the calibration instructions which may be found in the Installation and Service Manual.



## Reach and Coverage

### Horizontal Arm Lengths

The reach of the system is measured from the tip of the Cone with the arm fully extended and the Cone pointing back toward the pivot of the wall plate. This measurement method accommodates the normal positioning of the Tubehead to the patient. A patient can, therefore, be positioned without difficulty with the chair located within a radius outward from the pivot point to the dimensions shown in the diagrams.

The VetVision DC Horizontal Arm is available in four lengths. Each length gives the system a different reach. Catalog P7015 with a 30-A2074 Horizontal Arm has a reach of 56 inches. Catalog P7016 with a 30-A2073 Horizontal Arm has a reach of 66 inches. Catalog P7017 with a 30-A2071 Horizontal Arm has a reach of 76 inches. Catalog P7018 with a 30-A2164 Horizontal Arm has a reach of 82 inches. The diagrams show Catalog P7018 with a 82-inch reach. For Catalog P7017 with a 76 inch reach, reduce the dimensions by 8 inches. For Catalog P7016 with a 66 inch reach, reduce the dimensions by 18 inches. For Catalog P7015, reduce the dimensions by 28 inches.

### Optional 12 Inch Cone

The 82-inch reach for Catalog P7018 assumes the use of the 8 inch Cone that is supplied with the system. If the optional 12 inch Cone (30-A2033) is used, the reach is reduced by 4 inches.

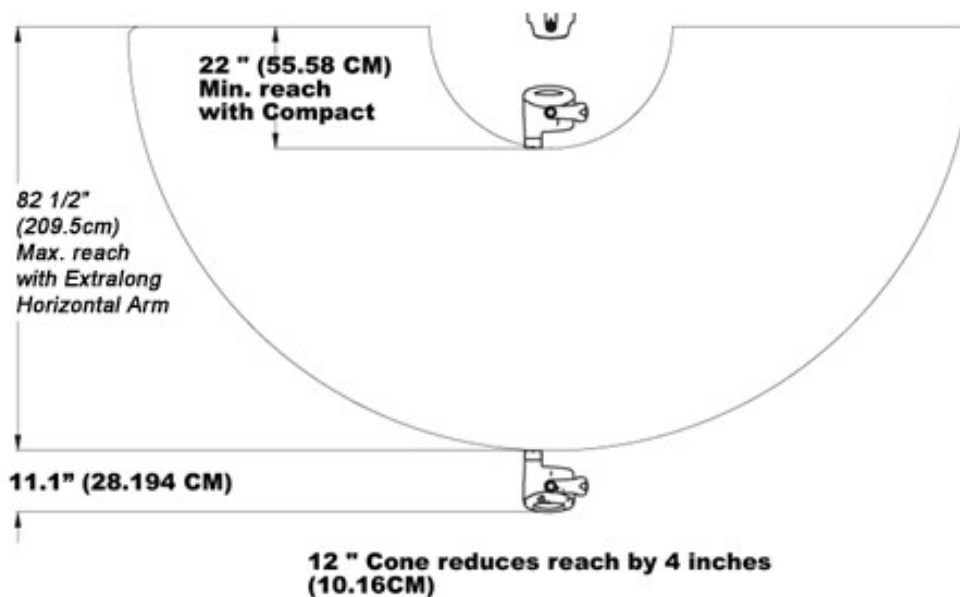


Figure 1  
Reach and  
Coverage  
Diagram

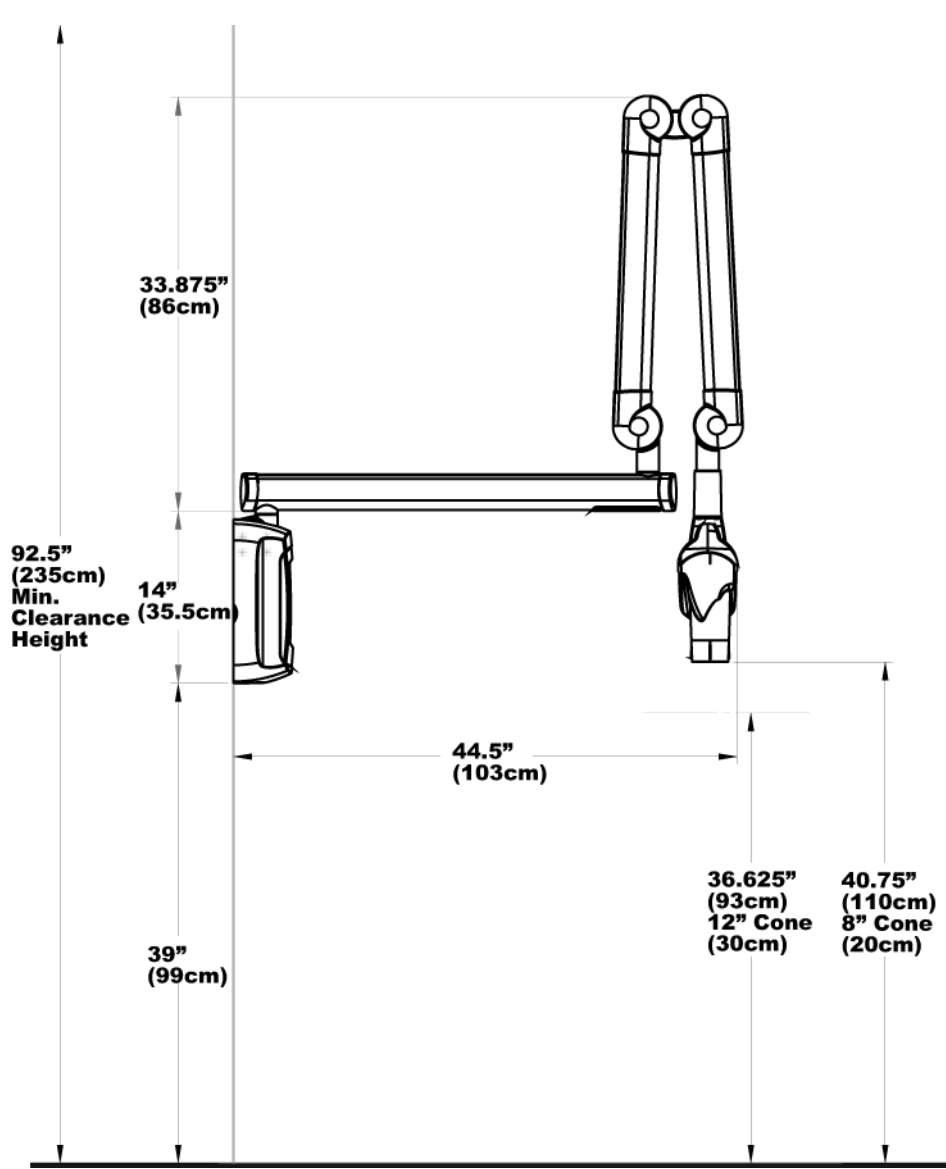


Figure 2  
Cabinet  
Mounting  
Dimensions

82" reach not recommended for cabinet mount

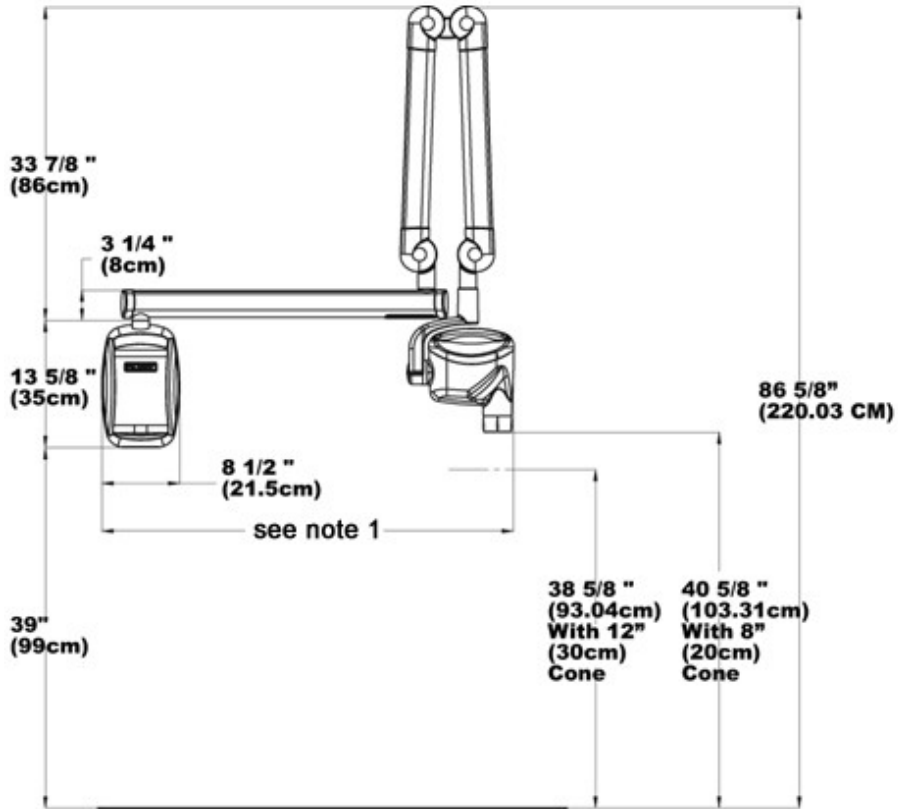


Figure 3  
Retracted Wall  
Mount

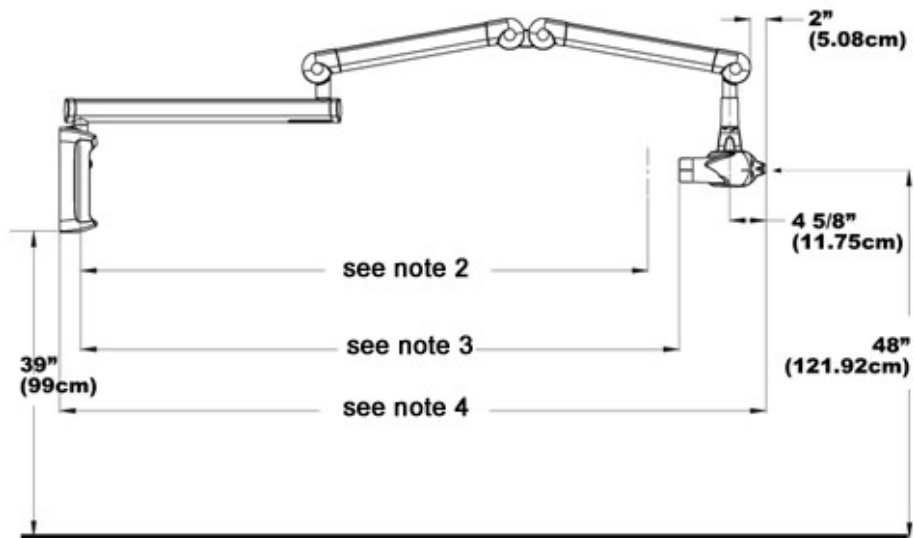


Figure 4  
Extended  
Position Wall or  
Cabinet Mount

note 2:	7015	52 1/2" (133 cm)	note 3:	7015	56 1/2" (143.5 cm)
	7016	62 1/2" (159 cm)		7016	66 1/2" (169 cm)
	7017	72 1/2" (184 cm)		7017	76 1/2" (194.5 cm)
	7018	78 1/2" (199 cm)		7018	82 1/2" (209.5 cm)
		<b>With 12" (30cm) cone</b>			<b>With 12" (30cm) cone</b>

note 3:	7015	70 3/8" (178.5cm)
	7016	80 3/8" (204 cm)
	7017	90 3/8" (229.5 cm)
	7018	96 3/8" (244.5 cm)

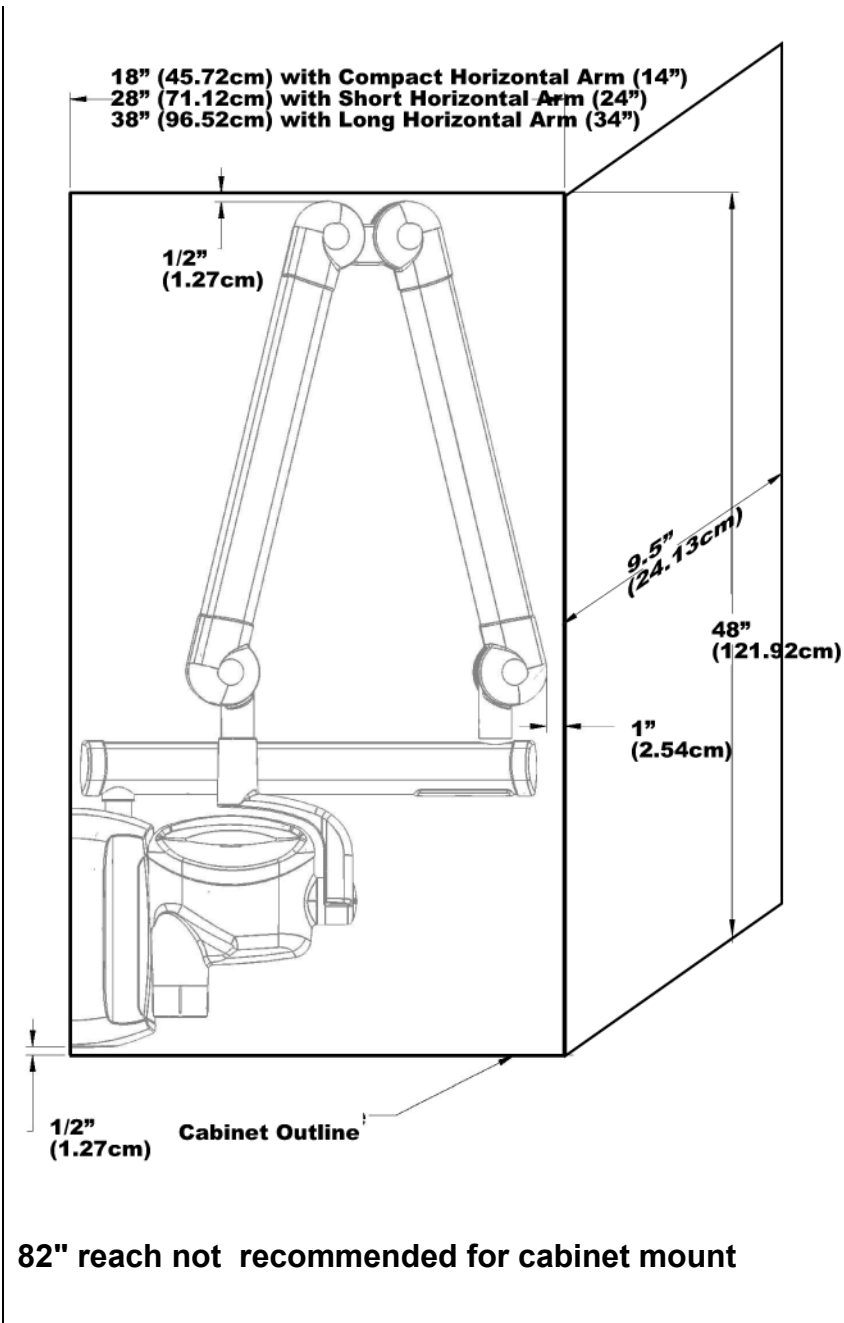


Figure 5  
Retracted  
Position for a  
Cabinet Mount

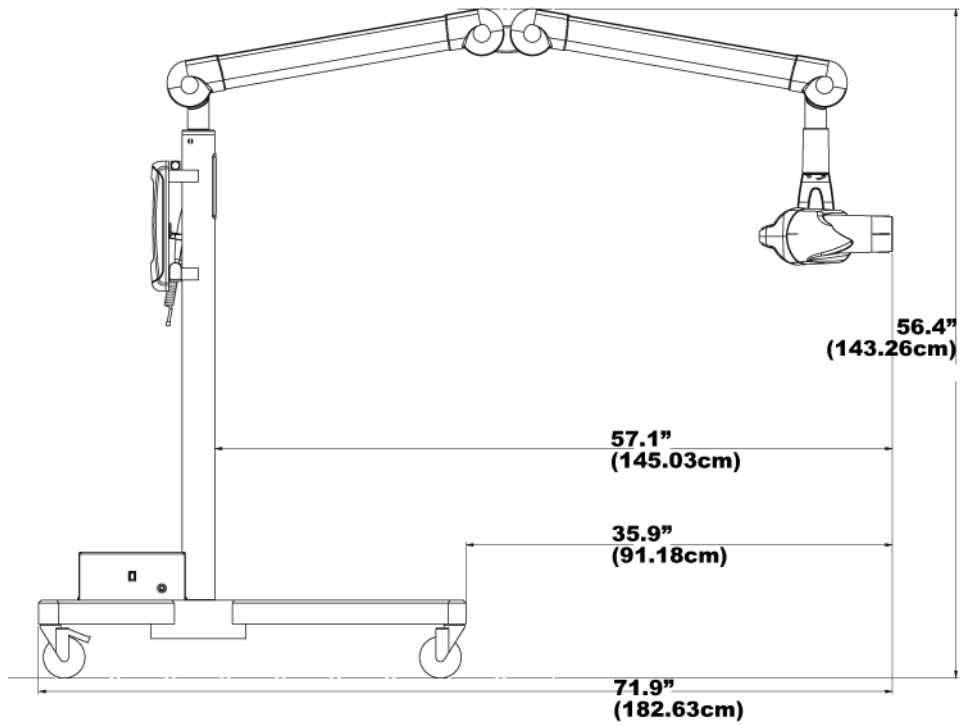
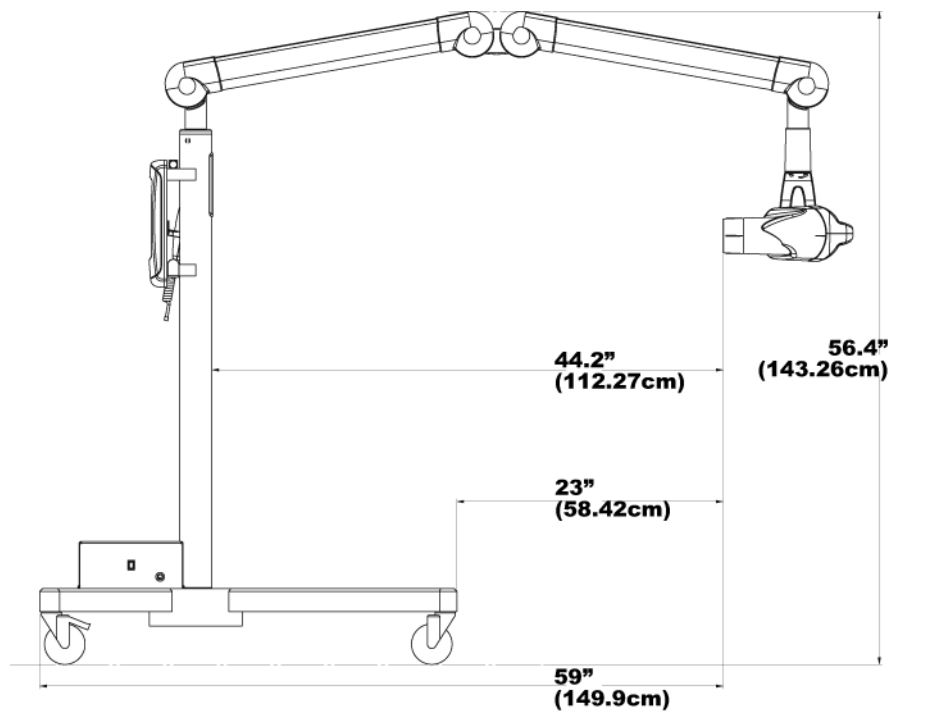


Figure 6  
Mobile Unit  
Extended

---

## Environmental Factors

### Use

The VetVision DC X-Ray System is intended for indoor use for normal dental applications at temperatures in the range +50 F/+95 F (+10 / + 35 C) and at a maximum altitude of 12,000 feet. Humidity should not cause condensation to form on the unit.

### Storage

Storage temperature should not exceed the range -31 F / + 150 F (-35 C / + 66 C).

## Support Requirements

The VetVision DC X-Ray System is designed to mount on a single wood 2x4-inch drywall stud or equivalent wall support. It can also be mounted on concrete or other similar wall construction. **Mounting to a plywood or particle board wall is not acceptable.** Verifying the wall support capability and the selection of the proper mounting hardware is the responsibility of the installer.

Please note that a two-stud wall plate assembly (30-A2042) is available as an option to mount on two wooden studs. Assembly (30-A2043) is available as a metal stud mounting kit.

The wall support and mounting hardware for the VetVision DC must withstand a 100 lb. (45.36 kg) shear load and a 400 lb. (182 kg) withdrawal force at each of the mounting bolts. The wall fabrication and attachments to the building structure must be capable of withstanding a load moment of 850 ft. lbs. (118 kg.m.).

## Electrical Requirements

<b>Main Power Supply</b>	The VetVision DC X-Ray System requires a three-wire electrician-supplied power supply. Two power lines, Line (LINE) and Neutral (NEUT), and a Ground (GND) are required. It is recommended that the unit be installed with a dedicated electrical line connected to a breaker with a minimum 15 amp rating. The wiring must provide for a permanently grounded power line configuration.	
<b>Line Cord Use</b>	The installer must determine the suitability of installing the VetVision DC with a line cord. If a line cord is used, the installer must ensure that the unit is properly grounded and has the required line rating.	
<b>Line Voltage</b>	Nominal 100 - 230 VAC +/- 10%	
<b>Fuse Rating</b>	5A 250V UL Recognized	
<b>Max Line Resistance</b>	<b>Nominal Voltage</b> 120 - 230 VAC	<b>Line Resistance</b> 0.4 ohm

## Compliance with Applicable Standards

<b>Radiation Protection</b>	<p>The certified components of the VetVision DC X-Ray System comply with Radiation Performance Standards 21 CFR, Subchapter J, at the time of manufacture.</p> <p>The certified components of the VetVision DC X-Ray System comply with IEC 60601-1-3 Radiation protection/x-ray equipment.</p>
<b>UL 2601-1 File Number: E181750</b>	Classified by Underwriters Laboratories Inc. with respect to electrical shock, fire and mechanical hazards only in accordance with UL 2601-1, and CAN/CSA C22.2 NO, 601.1-M90, and to the following particular standards, IEC60601-2-7, IEC60601-2-28.
<b>EMI/EMC</b>	IEC60601-1-2

## Certified Components

<b>System</b>	<b>Component</b>	<b>Reference Number</b>
	Tubehead	30-A1027
	Control Unit	30-A1041
	Cone 8 in.	30-A2016

## EC Declaration of Conformity

**Name and Description of Product**

**Progeny VetVision DC**

Catalog Model	P7017V, 76-inch reach 30-A1041, Control 30-A1028, Articulated Arm
---------------	---

Catalog Model	P7016V, 66-inch reach 30-A1041, Control 30-A1028, Articulated Arm
---------------	---

Catalog Model	P7015V, 56-inch reach 30-A1041, Control 30-A1028, Articulated Arm
---------------	---

Catalog Model	P7017VM, Mobile 30-A1032, Control
---------------	--------------------------------------

**Reference Numbers to which Conformity is Declared**

The following regulatory documents apply:  
 UL 2601-1  
 IEC 60601-1-2  
 IEC 60601-1-3  
 IEC 60601-2-7  
 IEC 60601-2-28  
 IEC 60601-2-32

**Contact**

Technical Support



## Authorized Representatives

### North America

MIDMARK CORPORATION  
675 Heathrow Dr.  
Lincolnshire, IL 60069  
Phone: 888-924-3800  
Fax: 847-415-9801

### Europe

CE Partner 4U  
Esdoornlaah 13  
3951DB Maarn  
The Netherlands  
Phone: +31.343.442.524  
Fax: +31.343.442.162

## Safety

### Radiation Safety

Only qualified and authorized personnel may operate this equipment observing all laws and regulations concerning radiation protection.

- The operator at all times must remain 6ft. (2m) from the focal spot and the x-ray beam for operator protection.
- Full use must be made of all radiation safety features on the equipment.
- Full use must be made of all radiation protection devices, accessories and procedures available to protect the patient and operator from x-ray radiation.







### Electrical Safety

- Only qualified and authorized service personnel should remove covers on the equipment.
- This equipment must only be used in rooms or areas that comply with all applicable laws and recommendations concerning electrical safety in rooms used for medical purposes, e.g., IEC, US National Electrical code, or VDE standards concerning provisions of an additional protective earth (ground) terminal for power supply connection.
- Before cleaning or disinfecting, this equipment must always be disconnected from the main electrical supply.
- The VetVision DC X-Ray System is ordinary type medical equipment without protection against ingress of liquids. To protect against short-circuit and corrosion, no water or any other liquid should be allowed to leak inside the equipment.

### Explosion Safety

This equipment must not be used in the presence of flammable or potentially explosive gases or vapors, which could ignite, causing personal injury and/or damage to the equipment. If such disinfectants are used, the vapor must be allowed to disperse before using the equipment.

## Explanation of Symbols on Technical Labels

	Type B: Protection against electric shock (IEC 60601.1-1)
	Consult written instructions in User's Manual.
	ATTENTION RAYONS-X: OPERATION SEULEMENT PAR DU PERSONNEL AUTORISE. VOIR MANUEL DE L'OPERATEUR.
	WARNING X-RAY THIS X-RAY UNIT MAY BE DANGEROUS TO PATIENT AND OPERATOR UNLESS SAFE EXPOSURE FACTORS AND OPERATING INSTRUCTIONS ARE OBSERVED.
	<i>X-RAY EMISSION</i>
<b>L</b>	Mains HOT WIRE
<b>N</b>	Mains NEUTRAL WIRE
	Earth Ground

## Obtaining Technical Support

<b>Contact</b>	MIDMARK CORPORATION 675 Heathrow Dr. Lincolnshire, IL 60069 Phone: 888-924-3800 Fax: 847-415-9810
----------------	---

# Installation Options

## Mounting Configurations

### Mounting Template

This section gives instructions for installing the VetVision DC X-Ray System in three mounting configurations. Use the mounting template, shown in Figure 7, to guide single stud installations. Reverse the template for dual-stud installations.

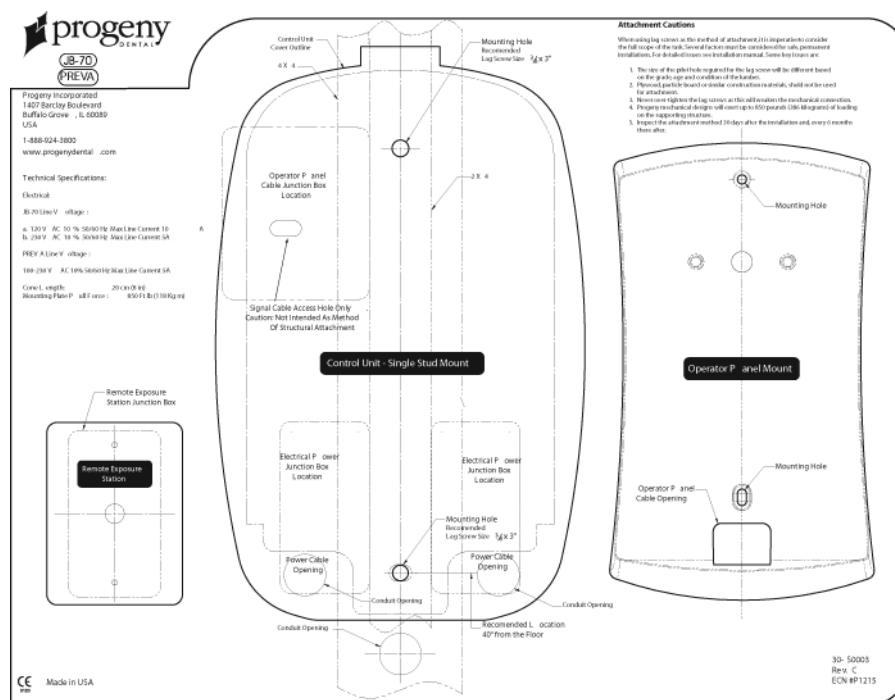


Figure 7  
Mounting Template

**CAUTION:**  
When installing the intraoral system, combined with the 82 inch (209 centimeter) reach arm, wall fabrication and attachments to the building structure must be capable of withstanding a load moment of 920 pounds (418 kilograms).

**CAUTION:**  
Lag screws are not intended to be used as an attachment method for metal supports such as those found in center island pass-through cabinets. Progeny provides machine screws, large flat washers and nylock nuts to use when fastening the system to metal supports.

**Single Wood Stud Wall, Solid Wall, or Reinforced Wood Cabinet**

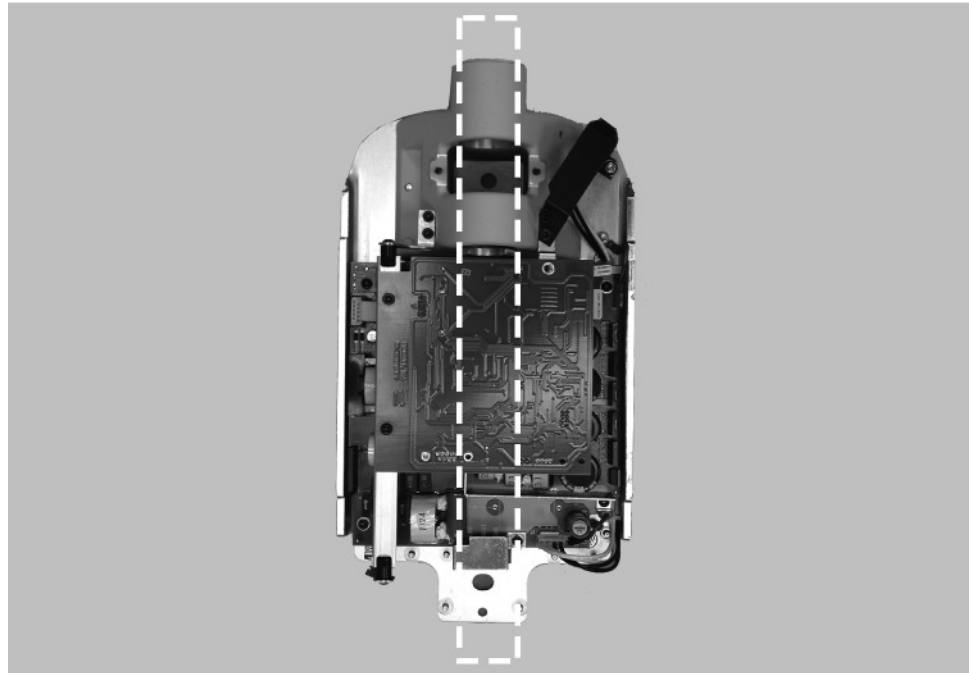
The Control Unit should be located at a height of 39 inches (99 cm) from the floor to the bottom of the control, mounted on the wood stud, as shown in Figure 8. The large range of travel of the Articulating Arm provides some flexibility in the vertical position. Two mounting holes are provided. Refer to the supplied mounting template, shown in Figure 7, for specific locations.

When installing in a reinforced wood cabinet, refer to the manufacturer of the pass-through box or cabinet for proper mounting configuration and height. Refer to the supplied mounting template for specific locations of power supply and/or Operator Panel cable access points.

In order to mount to a solid, masonry type wall, the same mounting holes and mounting template as the single wood wall stud are used. The installer must supply appropriate fasteners.

The power supply 2x4 junction box should be mounted to the left of the mounting stud at the appropriate height, as indicated in the mounting template.

**Note:** A 4x4 junction box will not be covered by the Control Unit. Refer to the supplied mounting template for specific location.



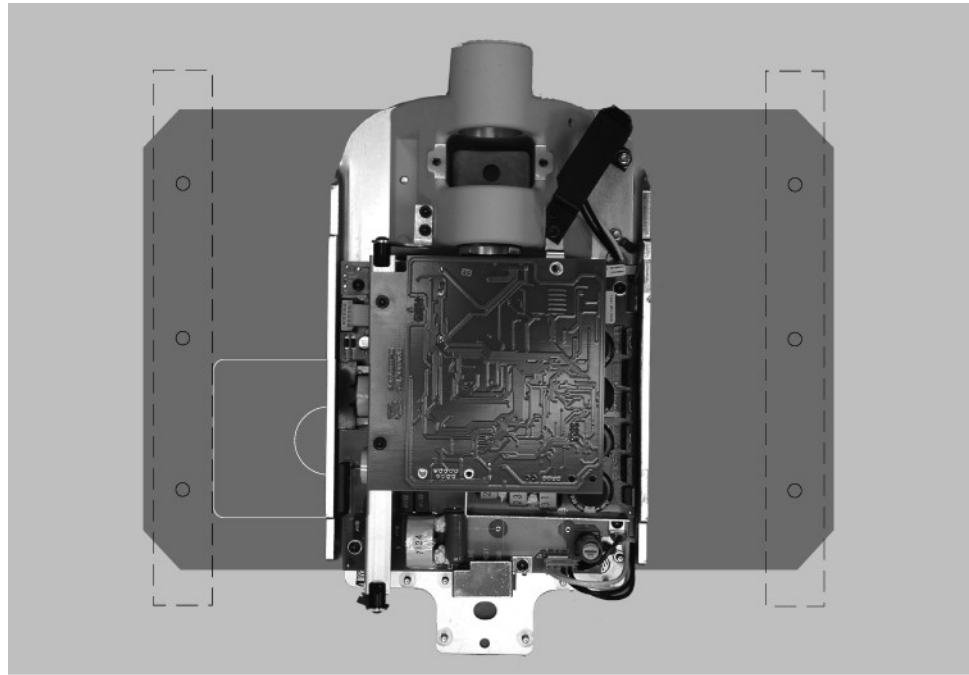
**Figure 8**  
**Wood Wall Stud**  
**Mount**

**WARNING:**  
**UNDER NO CIRCUMSTANCES SHOULD THE 82 INCH (208 CM) REACH SYSTEM BE ATTACHED TO A WALL IN THE SINGLE STUD CONFIGURATION. PLEASE DIRECT ANY QUESTIONS ON THIS MATTER TO THE PROGENY TECHNICAL SUPPORT GROUP.**

**Dual Wood Stud Wall**

When installing the VetVision DC X-Ray System on two 16-inch centered wood studs, the Control Unit mounts to a wall plate (Two Stud Mounting Kit 30-A2042, purchased as an option), which mounts to the wood studs, as shown in Figure 9. Fasteners are provided with the wall plate.

In mounting configurations using the dual stud wall plate, there are several holes available for incoming line power. This is to provide for various locations of existing power boxes when installing as a replacement unit. Refer to the reverse side of the mounting template, Figure 7, for hole locations.

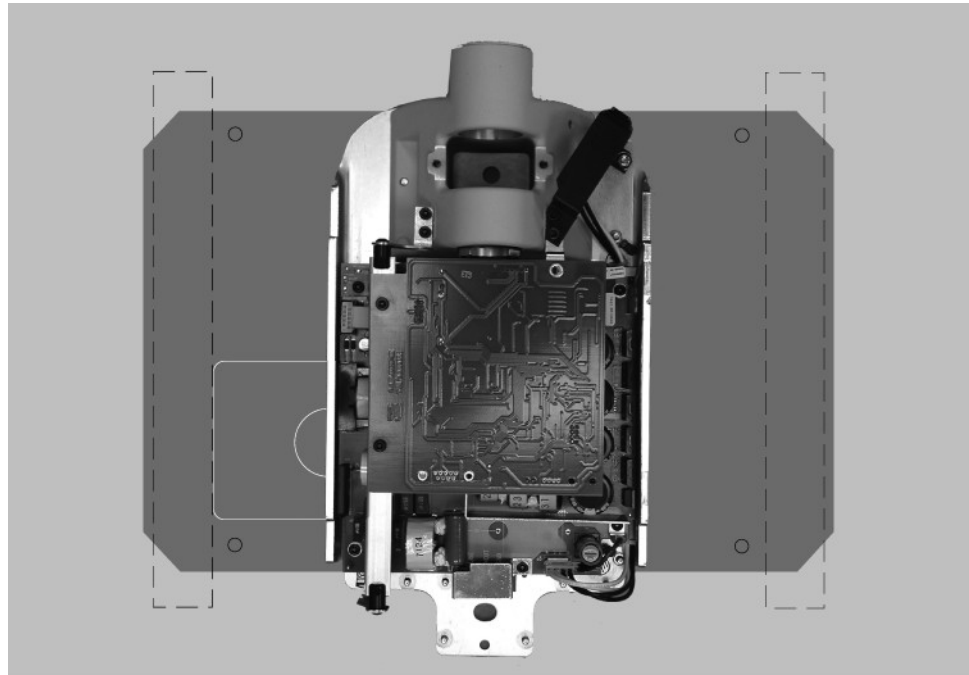


**Figure 9**  
**Dual Wood Stud**  
**Mount**

**Metal Stud Wall**

When installing the VetVision DC X-Ray System on a metal stud wall, the Control Unit mounts to a wall plate (Two Stud Mounting Kit 30-A2042, purchased as an option) and uses an additional support plate (Metal Stud Support Plate Kit 30-A2043, purchased as an option) positioned on the back end of the wall. See Figure 10. Fasteners are provided with the wall plate and support plate. The wall fabrication and attachments to the building structure must be capable of withstanding a load moment of 850 ft. lbs. (118 kg.m.). If the wall on which the VetVision DC is to be installed does not meet this requirement, it must be reinforced.

In mounting configurations using the dual stud wall plate, there are several holes available for incoming line power. This is to provide for various locations of existing power boxes when installing as a replacement unit. Refer to the mounting template in Figure 7 for hole locations.



**Figure 10**  
**Metal Stud Mount**

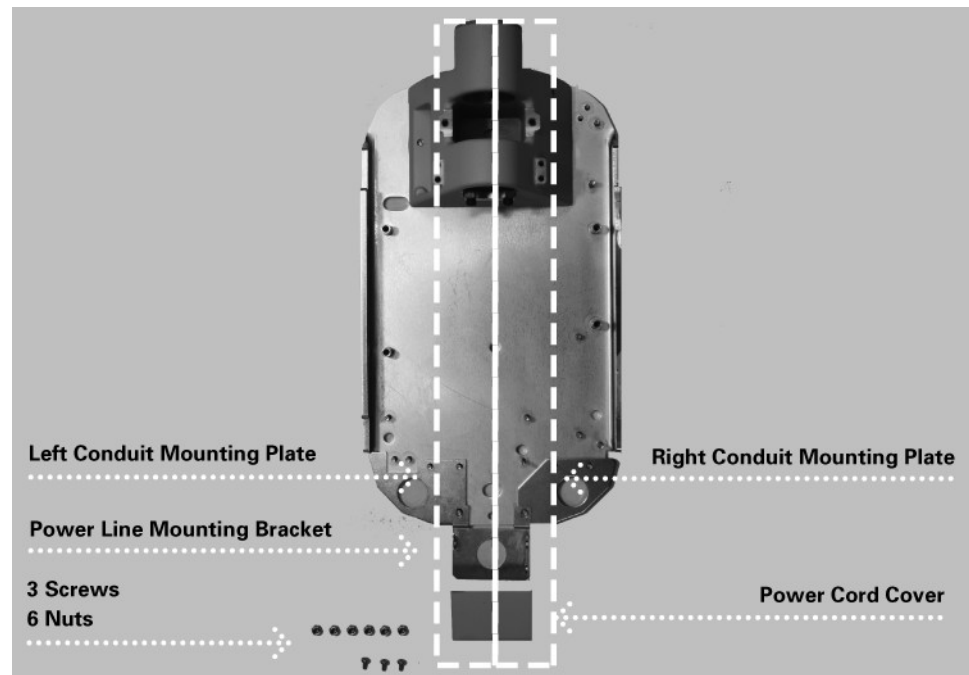
## Installing the 4x4 Mount

The 4x4 Mount kit (30-A2099), shown in Figure 11, contains the items below:

- Power line bracket
- Power cord cover
- Left conduit mounting plate
- Right conduit mounting plate
- 3 Phillips screws
- 6 nuts

## Instructions

1. Using the three Phillips screws, secure the power line bracket to the power line cord cover.
2. Place the right and left conduit mounting plates on the control.
3. Place the assembled power line bracket and cord cover on the two bottom-most threaded studs.



**Figure 11**  
**4x4 Mount Cabinet**  
**Layout**

## Operator Panel Locations

	<p>The Operator Panel for the VetVision DC X-Ray System can be installed on the Control Unit or mounted remotely on a wall.</p>
<b>On Control Unit</b>	<p>The Operator Panel snaps on to the front of the Control Unit. Installation of the Operator Panel on the Control Unit may require the purchase and use of the coil-cord hand switch option, 30-A2040.</p>
<b>Remote Operator Panel</b>	<p>The Operator Panel is mounted on the wall remote from the Control Unit.</p> <p>If the Operator Panel is mounted separate from the Control Unit, a supplied cable must be run from the Control Panel to the Operator Panel. Where local codes require, a separate 2x4 junction box should be mounted to the left of the mounting stud above the power supply box. Refer to the supplied mounting template for specific location.</p>



# Installation Procedures

## Preparing to Install the VetVision DC

### Check Pre-installation Requirements

Prior to beginning the installation, be sure that all pre-installation requirements have been completed. This includes confirming that the wall support requirements are adequate for mounting the unit and that the electrical power requirements and wire locations are proper.

**Note:** Progeny recommends that the VetVision DC X-Ray System be connected to dedicated wiring and permanently grounded. The installer must determine the suitability of using a line cord at the time of installation, ensuring proper grounding technique.

### Gather Tools

Items needed for all types of mounts:

- Stud finder
- Bubble level (torpedo level)
- Masking or other tape for placing the mounting template on the wall
- Awl
- Drill driver and drill bits appropriate to type of wall mounting
- Metric Allen wrench set
- English (inch) Allen wrench set
- Screwdrivers (flat-blade and Phillips)
- Torque wrench 0-40 ft-lbs. or equivalent
- Sockets and ratchet driver appropriate to type of wall mounting
- Fluke model 73 DVM equivalent or better
- Small test clips (such as Pomona Electronics Minigrabber Test Clip Model 6248 or Radio Shack Mini-Hook Adapters catalog # 270-334)

Items needed only for the metal stud wall mount:

- 1-inch hole saw
- Dry wall saw
- 1/4-inch diameter 12-inch long drill bit
- Two 4x4 wood studs
- Drywall screws

### Installation Time

The VetVision DC X-Ray System has been designed to be installed by one person in less than one hour, assuming that all pre-installation requirements have been met.

### Open the Shipping Carton

The VetVision DC X-Ray System is shipped in a convenient two-level carton, as shown in Figure 12. The first level contains the items needed for the first part of the installation, including the Control Unit, Operator Panel, Horizontal Arm, mounting template, documentation, cables, and bags containing the mounting hardware, brake assembly plastic covers, and additional hardware. The Articulating Arm and Tubehead Assembly is in the second level of the shipping carton, where it can remain until it is installed.



Figure 12  
Two-level Carton

**Packing List**

Part Number	Description	Quantity
30-A1028	Articulated Arm Assembly	1
30-A1041	Control Unit Assembly	1
30-A2123	Operator Panel	1
30-P0029	Operator Panel Mounting Cradle	1
30-A2049	Brake Assembly Kit	1
30-A2046	Mounting Hardware Kit	1
E1-13002	Line Cord, 16/3 6' Long	1
E1-13003	8 Cond. RJ45 to RJ45 25 ft.	1
E1-13004	8 Cond. RJ45 to RJ45 6 in.	1
30-A2139	VetVision DC Documentation Kit	1
30-A2068	Art. Arm Brake Assembly Kit	1
30-A2092	Plastic Parts Kit, Preva	1
30-P0076	Installation Guide	1
<b>Note: Shipment Contains One of the Following Extension Arms Per Order</b>		
30-A2071	Extension Arm, Long	1
30-A2073	Extension Arm, Short	1
30-A2074	Extension Arm, Compact	1

## Installing the Control Unit on a Single Wood Stud Wall

### Mark and Drill Control Unit Mounting Holes

**WARNING:**  
UNDER NO CIRCUMSTANCES SHOULD THE 82 INCH (208 CM) REACH SYSTEM BE ATTACHED TO A WALL IN THE SINGLE STUD CONFIGURATION. PLEASE DIRECT ANY QUESTIONS ON THIS MATTER TO THE MIDMARK TECHNICAL SUPPORT GROUP.

### SINGLE STUD INSTALLATION WITH THE “INSTALLATION GUIDE” (30-P0076).

#### Introduction

The Installation Guide is intended to be a positive means of locating the center of a 2x4 wooden stud. The Installation Guide is a necessary part of the installation and must be used whenever single stud installations are performed. The Installation Guide is equipped with side tabs which can be removed if placement of the Guide is obstructed by an electrical box. During installations which include attachment to a 4x4 wooden stud, all of the tabs, on one side of the guide, can be removed in order to facilitate adequate placement and attachment.

1. Locate the wooden stud.



2. Make a small opening in the wall to positively identify the position of the wooden stud.



3. Draw an outline of the installation guide on the wall, ensuring that the vertical height matches the requirements set forth on the “Wall Mount Template” (30-S0003). Open the wall so that the installation guide will rest directly on the wooden stud.



4. Place the installation guide on the wooden stud.



5. Drill two 5/32 inch diameter holes using the installation guide as a drill template.



6. Attach the wall mounted control, leaving the installation guide in place.



**Remove Control Unit Front Cover**

1. Open the shipping carton and locate the Control Unit in the first level of the carton.
2. Remove the Phillips screw from the front cover of the Control Unit.
3. Carefully remove the front cover.
4. Place the front cover and the screw in a safe location for later reassembly.

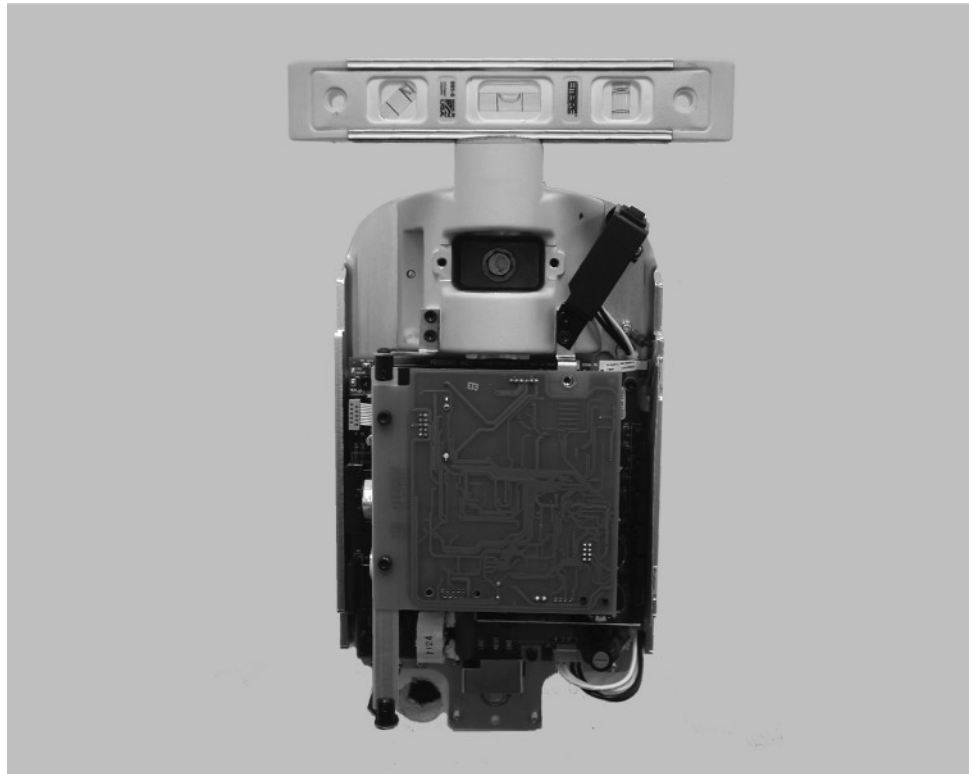
**Mount and Level the Control Unit**

1. Select the 3/8 inch 3-inch long lag screws and washers.  
**Note:** For concrete walls, the installer must supply the appropriate mounting bolts.
2. Put the upper lag screw and washer through the upper mounting hole of the Control Unit.
3. Place the Control Unit on the wall and loosely tighten the upper mounting bolt.
4. Put the lower lag screw and washer through the lower mounting hole of the Control Unit and loosely tighten. Be sure that the power wire extends through the opening at the bottom of the Control Unit.
5. Place a level on the Control Unit bearing parallel to the wall, as shown in Figure 13. Level the Control Unit.
6. Tighten the upper and lower lag screws to 14 to 18 ft-lbs.
7. Predrill a hole for a # 12 wood screw below the lower lag screw, as shown in Figure 14 A. Install and tighten the wood screw to prevent the unit from shifting.

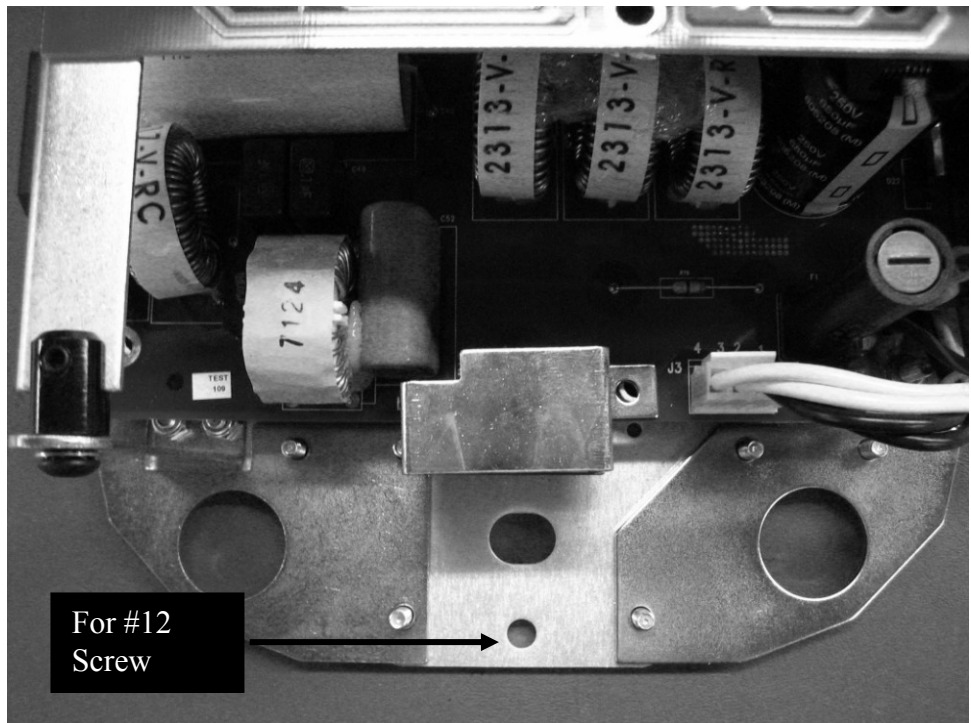
**CAUTION!**

**Do not over tighten the lag screws. Over tightening the lag screws will damage the wooden stud and reduce the holding force.**

**Figure 13**  
Leveling the  
Control Unit



**Figure 14 A**



## Installing the Control Unit on a Dual Wood Stud Wall

### Mark and Drill Wall Plate Mounting Holes

The mounting template is a guide for locating where to drill the holes used to mount the wall plate to the wall. Carefully placing the mounting template for two stud mount installations on the wall will help ensure correct installation of the mounting plate and, hence, the Control Unit.

1. Using a stud finder, locate the center of the studs on which the wall plate will be mounted.
2. Place the mounting template for the two stud mount on the wall with the lower mounting holes 40 inches above the floor.
3. Place a level parallel to the vertical lines on the mounting template and adjust the mounting template until it is plumb.
4. Tape the mounting template to the wall.
5. Using an awl or other sharp object, punch through the mounting template to mark the location of the mounting holes.
6. Drill 5/32" pilot holes (for common pine studs) at marked locations.
7. Remove the mounting template from the wall and save for future use.

### Install the Wall Plate (30-A2042)

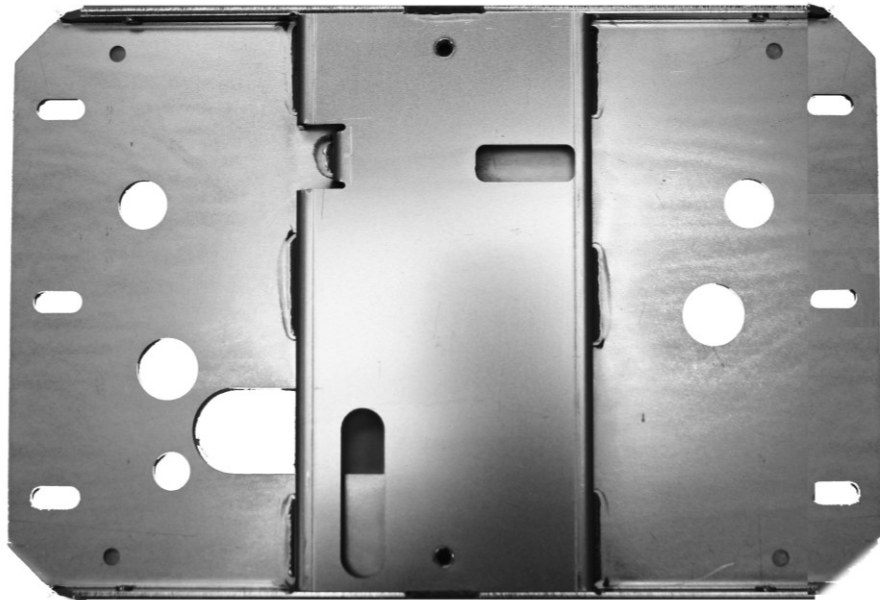
In the dual wood wall stud installation, the Control Unit is bolted to a wall plate that has been installed on two wood studs. The wall plate, shown in Figure 14, is shipped separately from the VetVision DC.

1. Select the 3/8 inch 3-inch long lag screws and washers.
2. Put the lag screws and washers through the mounting holes on the wall plate and loosely tighten. Be sure that the power wire extends through the opening in the wall plate.
3. Level the wall plate.
4. Tighten the lag screws to 14 to 18 ft-lbs.

#### **CAUTION!**

**Do not over tighten the lag screws. Over tightening the lag screws will damage the wooden stud and reduce the holding force.**





**Figure 14**  
**Mounting Plate for**  
**Dual Stud Wall**  
**Mounts**

### **Remove Control Unit Front Cover**

1. Open the shipping carton and locate the Control Unit in the first level of the carton.
2. Remove the Phillips screw from the front cover of the Control Unit.
3. Carefully remove the front cover.
4. Place the front cover and the screw in a safe location for later reassembly.

### **Mount the Control Unit**

1. Select the 5/16-inch  $\frac{3}{4}$ -inch long socket cap screws and washers.
2. Put the upper screw and washer through the upper mounting hole of the Control Unit.
3. Place the Control Unit on the wall and loosely tighten the upper screw.
4. Put the lower screw and washer through the lower mounting hole of the Control Unit and loosely tighten. Be sure that the power wire extends through the opening at the bottom of the Control Unit.
5. Place a level on the Control Unit bearing parallel to the wall. Level the Control Unit.
6. Tighten the upper and lower screws.
7. After the VetVision DC is installed, slide covers on the wall plate and screw on.

## Installing the Control Unit on a Metal Stud Wall

### Mark and Drill Wall Plate and Support Plate Mounting Holes

The mounting template is a guide for locating where to drill the holes used to mount the wall plate and support plate to the wall. Carefully placing the mounting template on the wall will help ensure correct installation of these plates and, hence, of the Control Unit.

1. Using a stud finder, locate the center of the stud on which the Control Unit will be mounted.
2. Place the mounting template for the dual stud mount on the wall with the lower mounting holes 40 inches above the floor.
3. Place a level parallel to the vertical lines on the mounting template and adjust the mounting template until it is plumb.
4. Tape the mounting template to the wall.
5. Using an awl or other sharp object, punch through the mounting template to mark the location of the mounting holes.
6. Drill ¼-inch pilot holes at marked locations.
7. Drill 1-inch clearance holes.
8. Remove the mounting template from the wall and save for future use.

### Reinforce Metal Stud Wall

Filler material is added to the wall to prevent the metal stud wall from being crushed during installation.

1. Cut an access hole 6 inches by 10 inches in size between the clearance holes.
2. Insert two 4x4 wooden studs in the access hole. Attach the studs to the rear drywall surface with drywall screws.

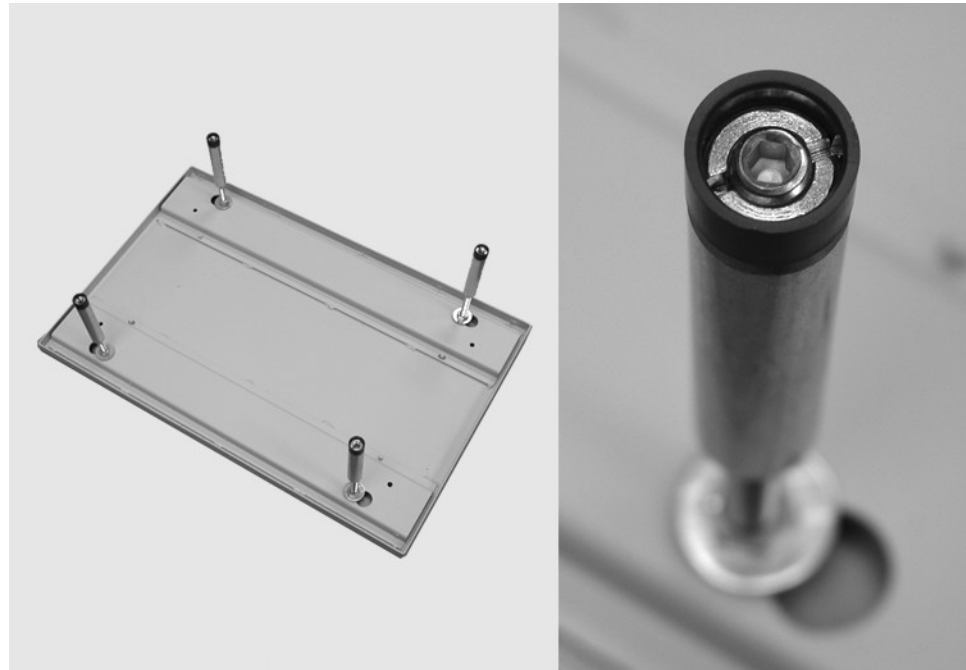
#### **CAUTION!**

**The sheet metal stud wall must be secure to hold a load of 850 ft. lbs. (118 kg.m.).**

### Assembling and Mounting the Support Plate (30-A2043)

In the metal wall stud installation, the Control Unit is bolted to a wall plate (Figure 14) that has been installed to the support plate shown in Figure 15. The wall and support plates are shipped separately from the VetVision DC.

1. Put the small, then the larger washers and nut on each of the four carriage bolts.
2. Insert the carriage bolts into the support plate holes.
3. Screw the threaded standoffs onto the carriage bolts with the slotted ends away from the back plate.
4. Place the plastic sleeve bearings in the slotted ends of the carriage bolts.
5. Using a 5/32 Allen key, insert a set screw into each threaded standoff. Screw the set screw until just below the slot in the threaded standoff, but do not tighten.
6. Using two sheet metal screws, mount and level the support plate through the pilot holes on the back side of the wall. Tighten the sheet metal screws with the screw driver.
7. On the front side of the wall, using a straight-blade screw driver, adjust the threaded standoffs until the plastic part is flush with the drywall.
8. Tighten the set screws in the threaded standoffs to lock them in place.



**Figure 15**  
**Support Plate for**  
**Metal Stud Wall**  
**Mount**

### **Install the Wall Plate (30-A2042)**

1. Select the 5/16-inch 1-inch long hex bolts.
2. Put the hex bolts through the mounting holes on the wall plate and loosely tighten. Be sure that the power wire extends through the opening in the wall plate.
3. Level the wall plate.
4. Tighten the hex bolts

### **Remove Control Unit Front Cover**

1. Open the shipping carton and locate the Control Unit in the first level of the carton.
2. Remove the socket flathead screw from the front cover of the Control Unit.
3. Carefully remove the front cover.
4. Place the front cover and the screw in a safe location for later reassembly.

### **Mount the Control Unit**

1. Select the 5/16-inch  $\frac{3}{4}$ -inch long socket cap screws and washers.
2. Put the upper screw and washer through the upper mounting hole of the Control Unit.
3. Place the Control Unit on the wall and loosely tighten the upper screw.
4. Put the lower screw and washer through the lower mounting hole of the Control Unit and loosely tighten. Be sure that the power wire extends through the opening at the bottom of the Control Unit.
5. Place a level on the Control Unit bearing parallel to the wall. Level the Control Unit.
6. Tighten the upper and lower screws.
7. After the VetVision DC is installed, slide covers on the wall plate and screw on.

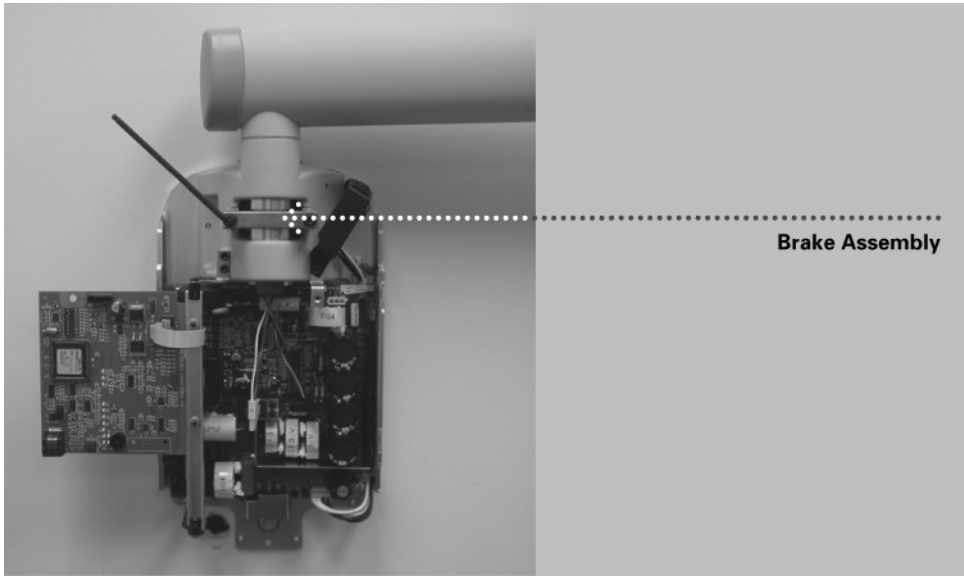
## Installing the Horizontal Arm and Brake Assembly

### Installing the Horizontal Arm and Brake Assembly

1. Locate the Horizontal Arm in the top level of the shipping carton.
2. Remove the Horizontal Arm from the shipping carton. **Do not remove** the cardboard tube around the wires but remove the red tag. Insert the cardboard tube snugly into the shaft of the Horizontal Arm.  
**Note:** Do not lubricate the shaft of the Horizontal Arm or bearings in Control Unit.
3. Insert the cardboard tube enclosing the wires into the opening in the top of the Control Unit.
4. Insert the Horizontal Arm completely into the Control Unit, as shown in Figure 16. Ensure that the Horizontal Arm is firmly seated in place.
5. Remove the cardboard tube to free the wires. Discard the cardboard tube.  
**Note:** Do not make the wire connections at this time.
6. Locate the brake assembly bag (30-A2049). As shown in Figure 17, install and loosely tighten the brake assembly in order to put a small amount of drag on the rotation of the Horizontal Arm and to keep the Horizontal Arm from lifting out.

Figure 16 Installing the Horizontal Arm





**Figure 17**  
**Installing the Brake**  
**Assembly**

## Installing the Articulating Arm and Tubehead Assembly

### Install the Articulating Arm and Tubehead Assembly

The Tubehead and Articulating Arm are installed as a single unit.

1. Remove the top level packing material from the shipping carton to gain access to the Articulating Arm and Tubehead Assembly. **Do not remove** the cardboard tube enclosing the cable wires but remove the red tag.
2. Remove the Articulating Arm and Tubehead Assembly from the shipping carton.

#### **CAUTION!**

**Do not remove the tie holding the Articulating Arm closed. Removing the tie will cause the Articulating Arm to spring open, potentially causing personal injury.**

**Note:** Do not lubricate the shaft of the Articulating Arm or the bearings in the Control Unit.

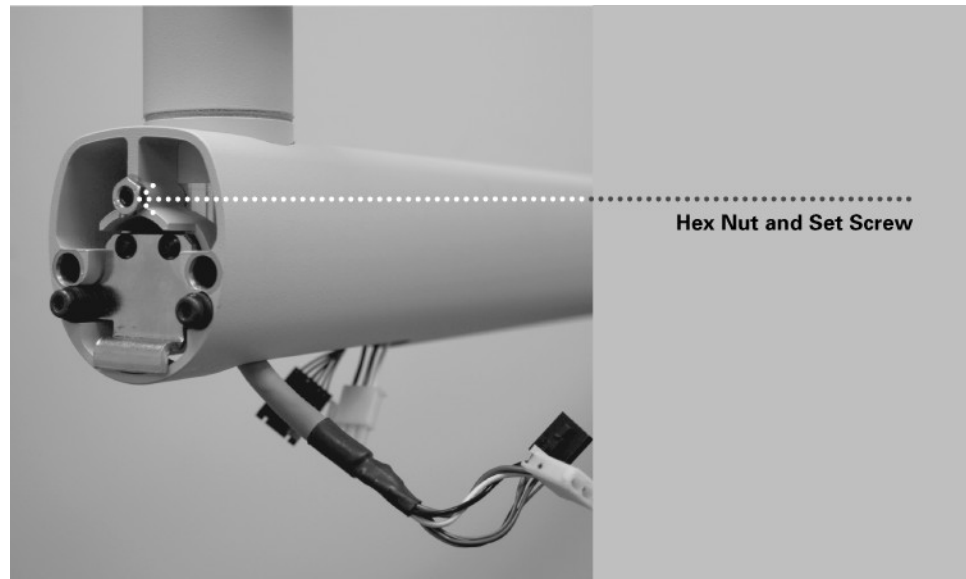
3. Position the Articulating Arm above the Horizontal Arm.
4. Carefully route the cardboard tube with the arm cable plug through the opening in the Horizontal Arm.
5. Insert the shaft of the Articulating Arm into the opening in the Horizontal Arm, as shown in Figure 18.
6. Press down until the shaft is completely seated in the Horizontal Arm.
7. Remove the cardboard tube to free the wires. Discard the cardboard tube.
8. Untie the Articulating Arm and remove the plastic covering.

Figure 18 Installing the Articulating Arm and Tubehead Assembly

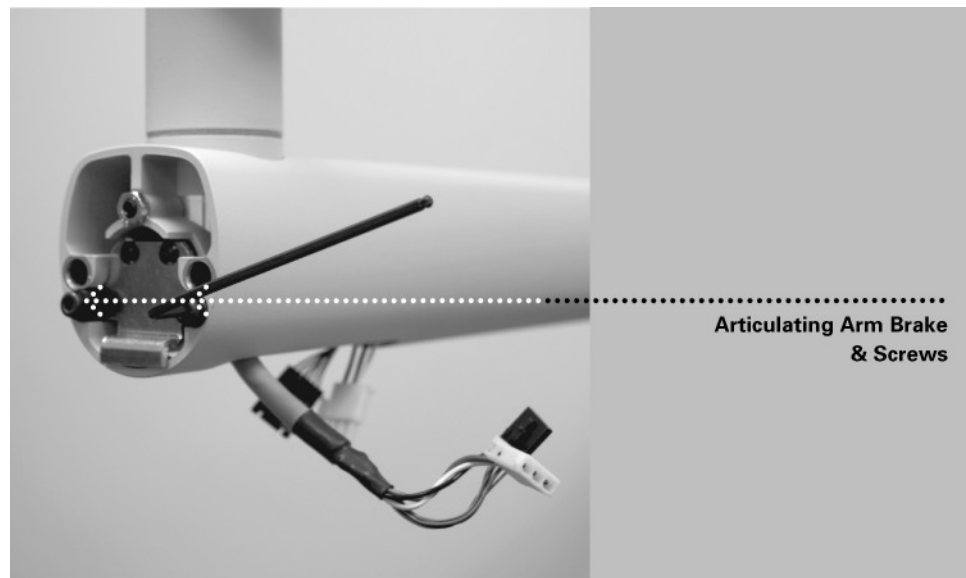


## Install the Articulating Arm Brake Assembly

1. Locate the Articulating Arm brake assembly (30-A2068).
2. Insert the M6 x 25 mm long set screw, as shown in Figure 19. Using a 3 mm Allen wrench, tighten the screw fully then back off  $\frac{1}{4}$  and secure with the hex nut.
3. Using a 3 mm Allen wrench, install the Articulating Arm brake. Tighten screws until the Articulating Arm brake comes into contact with the shaft of the Articulating Arm. If additional friction is required to prevent drifting, turn the two screws evenly  $\sim\frac{1}{4}$  turn at a time until drift stops, as shown in Figure 20.



**Figure 19**  
Installing the Hex Nut and Set Screw



**Figure 20**  
Adjusting the Articulating Arm Brake Assembly

## Connecting the Cables

### Connecting the Articulating and Horizontal Arm Cables

1. Connect the two Articulating Arm cables to the Horizontal Arm cables, as shown in Figure 21 and 22A.
2. Once the connections are made, dress the cables and push into the opening in the Horizontal Arm.

**Figure 21**  
Connecting the Articulating Arm and Horizontal Arm Cables



**Figure 22A**  
Connecting optional Integrated Sensor Cable



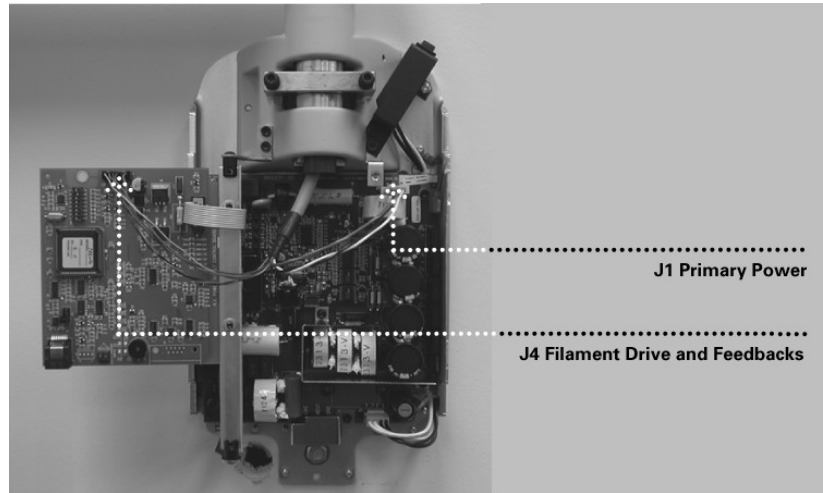


**Connecting the Horizontal Arm Cables to the Power Supply Board**

**CAUTION!**  
**Verify that line power is disconnected before proceeding.**

1. Attach the black connector from the Horizontal Arm to point J4 of the Power Supply Control Board 30-08043, as shown in Figure 22.  
**Note:** The plug must be properly oriented. Be sure that the tabs on the connector are down.
2. Attach the white connector from the Horizontal Arm to point J1 on the Power Supply Board 30-08041, as shown in Figure 22.  
**Note:** The plug must be properly oriented. Be sure that the tabs on the connector are down.

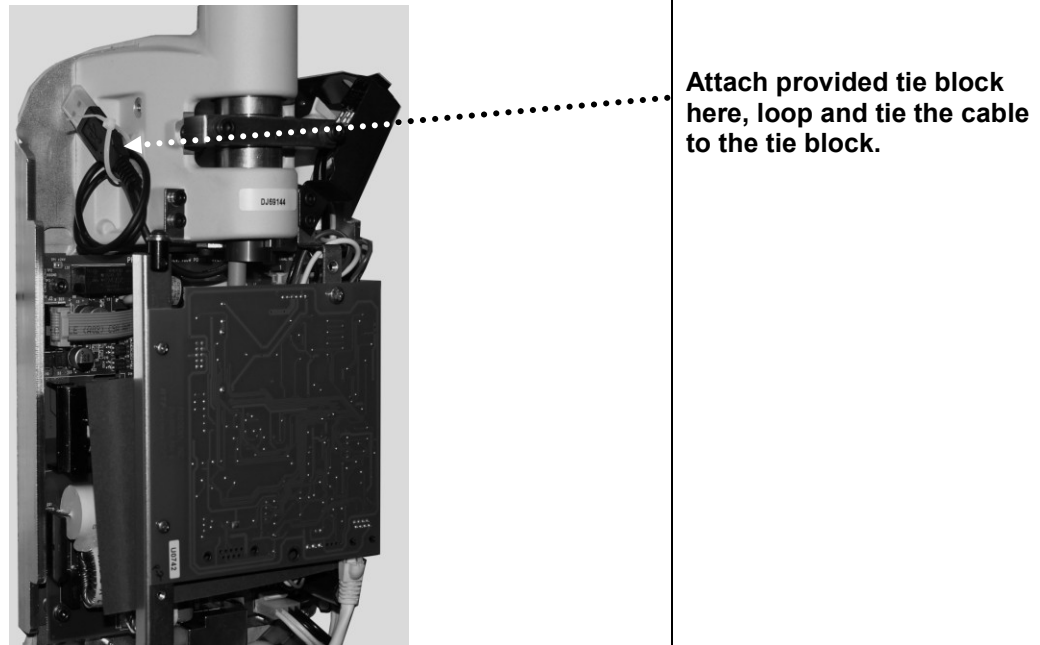
**Figure 22**  
**Connecting the Horizontal Arm Cables to the Circuit Boards**



**Optional Integrated Sensor**

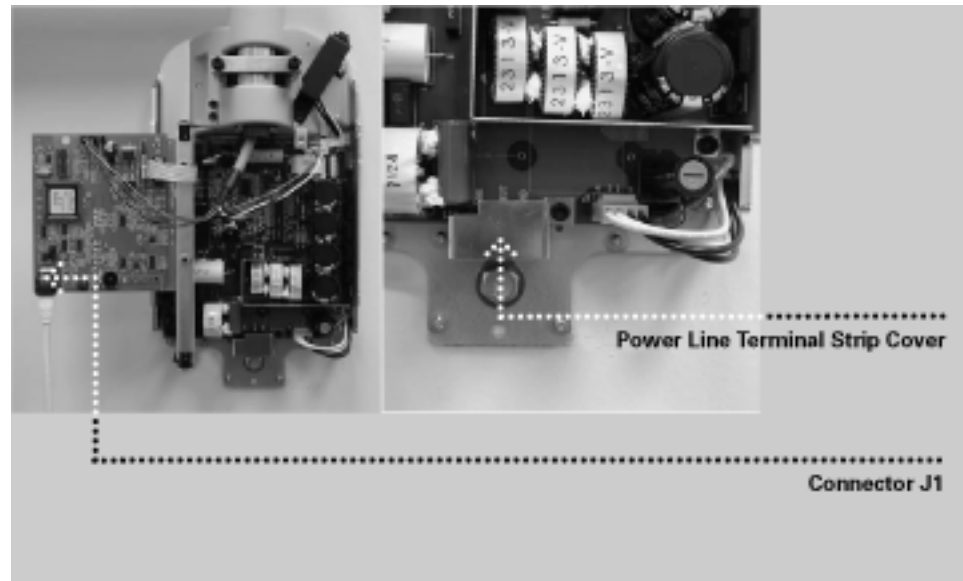
1. Optional integrated sensor cable. Ty-rap the USB cable to the tie block provided as shown in Figure 23A

**Figure 23A**  
**Tying optional sensor cable out of harms way**



## Connecting Line Power

1. Using a 3 mm Allen wrench, remove the power line terminal strip cover at the base of the Power Supply Control Board to gain access to the power line terminal strip, as shown in Figure 23.
2. Connect the hot (black) wire of the power line to the connection identified as LINE on the power strip.
3. Connect the neutral (white) wire of the line to the connection identified as NEUT on the power strip.
4. Connect the ground (green) wire of the line to the connection identified as GND on the power strip.
5. Leave the power line terminal strip cover off until the following electrical verification procedure is complete.



**Figure 23**  
Power Line  
Terminal Strip  
Cover

## Connecting the Operator Panel with the 25 ft. Cable

During initial powerup and verification, the Operator Panel is required. Connect the Operator Panel with the 25 ft. interconnect cable. Later you will connect the Operator Panel in its final position for use.

1. Identify the Operator Panel and the 25 ft. interconnect cable.
2. Plug the cable into the left socket at the base of the Operator Panel.
3. Plug the other end of the cable into connector J1 on the Power Supply Control Board 30-08043, as shown in Figure 23.

## Electrical Verification

### Calibration

Calibration of the VetVision DC X-Ray System is preset at the factory and is not required during initial installation. Service replacement of the Power Supply Control Board 30-08043 or the Tubehead will require calibration. See the Calibration section of this manual.

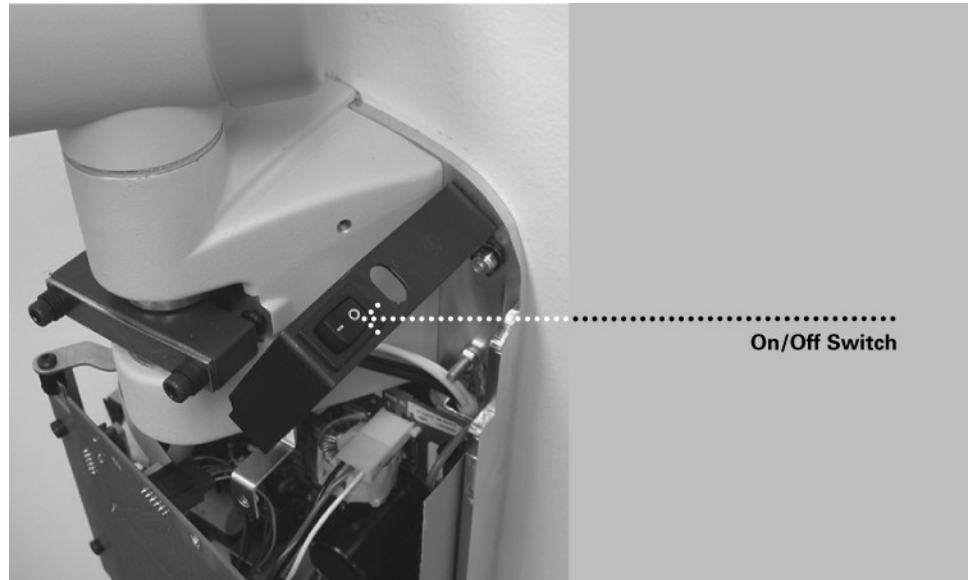
### Verifying Input Voltage and Turning On the System

1. Before turning on the system, verify the input voltage by measuring the voltage at LINE and NEUT, as shown in Figure 24. The reading should be within the range of 100 - 230V +/- 10%.
2. Replace the power line terminal strip cover.
3. Turn on the VetVision DC X-Ray System using the power switch, as shown in Figure 25. On the Operator Panel, Figure 26, you will see the product display screen showing the software version. Then the Operator Panel will display the default technique factors.



**Figure 24**  
Verifying Input Voltage at the Line Input

**Figure 25**  
Turning on the  
Power



**Figure 26**  
Operator Panel

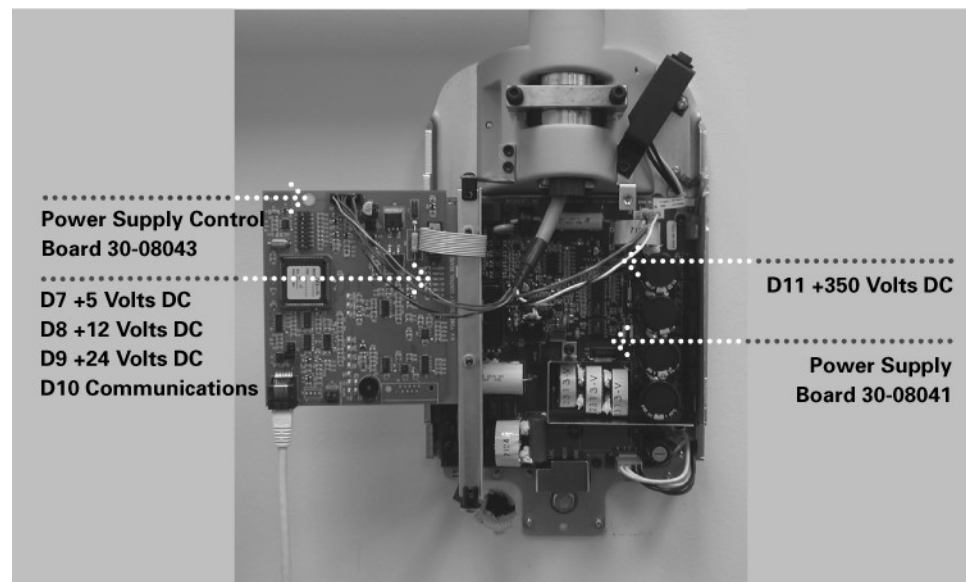


## Circuit Board Verification

**CAUTION!**

The Power Supply Board 30-08041, when energized, contains high electrical energy. Avoid contact with this board. After the system is turned off, electrical energy will remain in the Power Supply Board for several minutes. When attempting any service on this board, first verify that voltage has dissipated.

1. On Power Supply Board 30-08041, shown in Figure 27, verify that LED D11 is illuminated. The illuminated LED verifies that appropriate supply voltages are present.  
**Note:** Stored electrical energy is present whenever D11 is illuminated.
2. On the Power Supply Control Board 30-08043, shown in Figure 27, verify that LEDs D7 (+5VDC), D8 (+12VDC) and D9 (+24VDC) are illuminated and LED D10 is flashing. Each illuminated LED verifies that appropriate supply voltages are present. If the LEDs are not illuminated, refer to the “No Operator Display but Power Switch is On” procedure in the Troubleshooting section of this manual.
3. Turn off the VetVision DC X-Ray System using the power switch as shown in Figure 25.

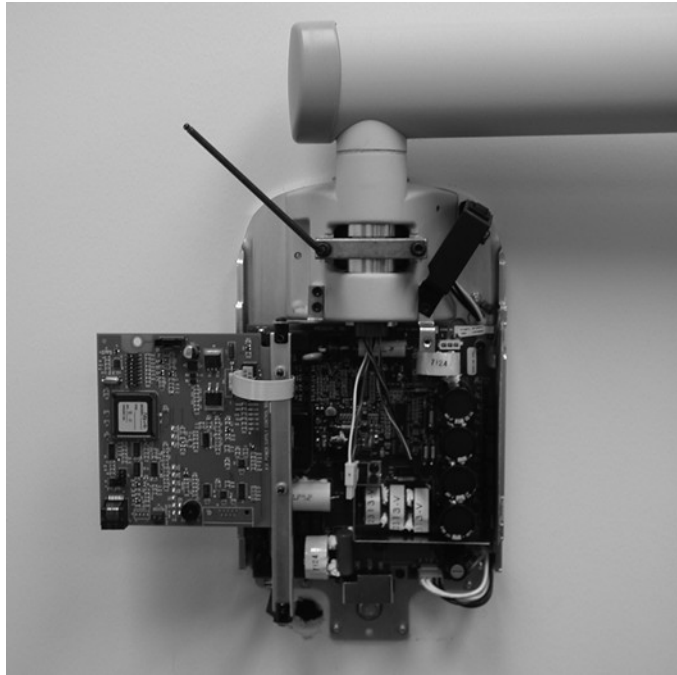


**Figure 27**  
Circuit Board Verification

## Mechanical Adjustments

### Horizontal Arm Adjustment

1. Locate the brake assembly at the top of the Control Unit. The brake assembly has a screw on either side of a clamping bar over the Horizontal Arm pivot post.
2. Using a 4 mm Allen wrench, as shown in Figure 28, tighten the screws equally to apply adequate braking to the pivot post so that Horizontal Arm begins to move after the Articulating Arm.



**Figure 28**  
Tightening the Brake

### Additional Adjustments

The balance and friction of the Articulating Arm are set initially at the factory. During the installation process, check the balance and friction. When moving the Tubehead, the Articulating Arm should be steady in all positions and move before the Horizontal Arm. If adjustments are necessary, follow the adjustment procedures in the Troubleshooting section.

**Note:** The mechanical adjustments should not be used to compensate for a system that is not properly leveled on the wall.

## Installing the Control Unit Front Cover and the Operator Panel

### Important Note

The Operator Panel can be installed on the Control Unit or remote from the Control Unit. Installation of the Operator Panel on the Control Unit may require the purchase and use of the coil-cord hand switch option 30-A2040.

In order to comply with the regulations and proper x-ray practices, the Operator Panel must be located where the operator can view both the patient and the technique factors prior to the exposure.

### On the Control Unit

1. Connect the short cable at point J1 on the Power Supply Control Board 30-08043.
2. Feed the cable through the front cover of the Control Unit.
3. Place the top of the front cover on the Control Unit and pop the bottom of the cover into place, as shown in Figure 29, being careful of the power switch and cover alignment.
4. Replace the screw on the front cover of the Control Unit.
5. Plug the cable into the bottom of the Operator Panel.
6. Snap the Operator Panel into place on the front cover of the Control Unit, as shown in Figure 30.



**Figure 29**  
Placing the Cover  
on the Control Unit



**Figure 30**  
**Snapping in the**  
**Operator Panel**



## Remote Operator Panel

In the remote location, the Operator Panel snaps to the Operator Panel mounting cradle, which is first mounted on the wall.

1. Place and level the mounting template, shown in Figure 7, at eye level in the location where the Operator Panel is to be installed. Tape the mounting template to the wall.
2. Using an awl or other sharp object, punch through the mounting template to mark the location for the bolts for the Operator Panel mounting cradle.
3. Drill pilot holes at marked locations. With a drywall knife, cut an opening as shown on the mounting template.
4. Remove the mounting template from the wall.
5. Using the anchors and screws from the mounting hardware bag, install the Operator Panel mounting cradle in the position marked.
6. Locate the 25-foot remote control cable.
7. Run the remote control cable, in compliance with local codes, from the intended location of the remote Operator Panel to the back of the Control Unit.  
**Note:** The cable can also be run to an electrical box or opening at the top left of the wall plate assembly. A sufficient length of cable should be left available to bring the remote cable out to the bottom front of the Control Unit.
8. Plug the remote control cable into the bottom of the Power Supply Control Board 30-08043.
9. Place the top of the front cover on the Control Unit and pop the bottom of the cover into place, as shown in Figure 29, being careful of the power switch and cover alignment.
10. Replace the screw on the front cover of the Control Unit.
11. Place the Progeny cover plate over the top opening and the small trim cover over the bottom opening on the front cover of the Control Unit.
12. Locate the Operator Panel in the top portion of the shipping carton.
13. Connect the other end of the remote cable to the right plug (as viewed from the back) on the bottom of the Operator Panel.
14. Carefully dress the white cable back into the wall.
15. Snap the Operator Panel to the mounting cradle, as shown in Figure 31.

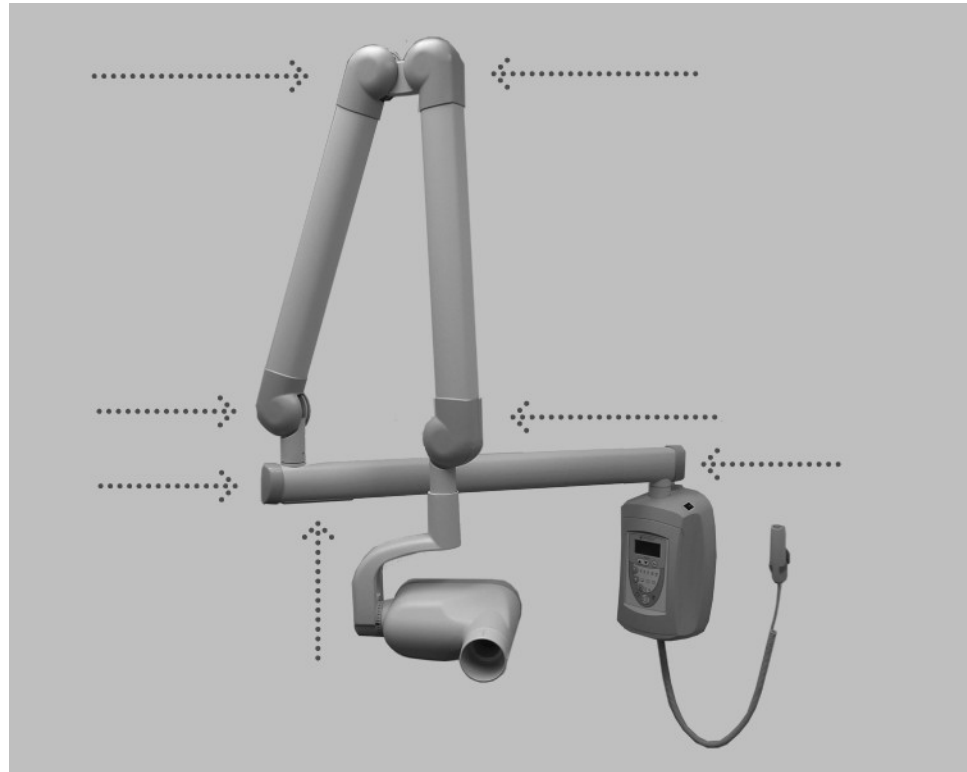


**Figure 31**  
**Snapping the**  
**Operator Panel to**  
**the Mounting Cradle**

## Installing Plastic Covers

The end cap for the Horizontal Arm is shipped in the bag of plastic parts and is put on as part of the installation procedures. End caps for the Articulating Arm are shipped installed but are removable to perform mechanical adjustments. The cable access cover is placed over the cable connection underneath the Horizontal Arm. Cover locations are shown in Figure 32.

1. Place the plastic cover from the miscellaneous plastic bag on the end of the Horizontal Arm.
2. Install the cable access cover over the Horizontal Arm opening using two Phillips flat-head screws.



**Figure 32**  
**Cover Locations**

## VetVision DC Operator Panel

### Using the Operator Panel

#### Power On Settings

When the VetVision DC X-Ray System is powered on, the Operator Panel, shown in Figure 33, displays the selections that were in use when the system was last powered off.

#### Exposure Settings

The Operator Panel displays the exposure settings (kV, mA, and seconds) for the currently selected tooth, image receptor type, and patient size. Use the Tooth Selection, Image Receptor Type, and Patient Size buttons to select other exposure settings.

#### Adjusting Exposure Settings

Preset exposure settings can be adjusted prior to making an exposure. Exposure time can be easily changed by simply using the up and down buttons. To adjust kV and mA, use the right arrow to select the exposure setting to adjust. Then use the up and down arrow buttons to adjust the value. To save new presets, use the System Configuration mode described later in this manual.

#### Exposure Button and Ready Indicator

The Exposure button is used to initiate an x-ray exposure. For a complete exposure, the button must be pressed and held until the Radiation Indicator no longer illuminates and the audible signal is no longer heard. Releasing the Exposure button immediately terminates the x-ray exposure.



**Figure 33**  
VetVision DC  
Operator Panel

## Checking System Functions

The following checks must be performed to complete the installation of the VetVision DC X-Ray System and as part of the recommended maintenance as indicated in the User Manual

**CAUTION!**

**If the VetVision DC X-Ray System does not perform the functions below, advise the owner that the system is not to be used. See the Troubleshooting section of this manual or contact Progeny's Technical Support.**

<b>System Function Checklist</b>		✓
<b>Wall Mounting</b>	Ensure that the wall support is adequate and that the system is properly mounted to the wall.	
<b>Labels</b>	Ensure that all certified components bear labels that include the model and serial number, date of manufacture, and a statement of certification as noted elsewhere in this manual.	
<b>Tubehead</b>	Check for oil leaks or other evidence that could indicate internal damage. Replace the Tubehead, if necessary.	
<b>Tubehead Rotation</b>	Ensure that the Tubehead maintains its position around the horizontal axis while remaining easy to rotate and position. Also check the vertical pivot of the Tubehead for easy movement while remaining in position after moving.	
<b>Suspension</b>	Check that all movements are smooth and quiet. Verify that the Tubehead is properly counterbalanced for vertical drift and that the Horizontal and Articulating Arms do not drift horizontally.	
<b>Power Switch</b>	Verify that the switch is working properly and that the Ready Indicator is illuminated when the power switch is in the ON position.	
<b>Operator Panel Controls</b>	With the power switch, located at the upper right of the Control Unit, in the ON position, verify that technique factors appear on the Operator Panel. Also, check the function of the selection buttons for Tooth Selection, Image Receptor Type and Patient Size. Pressing a selection button should cause indicator lamps to indicate the selected item.	
<b>Exposure Button</b>	Verify that the Exposure button on the Operator Panel is functioning properly. To make an exposure, press and hold the Exposure button until the Radiation Indicator is extinguished and the audible signal is no longer heard.	
<b>Exposure Indicators</b>	Make several exposures and verify that the Radiation Indicator illuminates and the audible signal is heard.	
<b>Premature Termination</b>	Select the longest exposure time possible using the up and down arrows. Initiate an exposure but release the Exposure button after a brief period of time before the timer terminates the exposure. Verify that the display indicates "Pre-termination Error" and returns to normal operating mode.	
<b>Coil-cord Hand Switch Option</b>	If a coil-cord hand switch is used, inspect the switch housing and coil cord for damage or wear. Replace if evidence of damage is present.	
<b>User Information</b>	Make certain that the user of the system has received the User Manual.	

## Tube Seasoning Procedure

**Note: Do not use this procedure if you have just replaced the head.**

Refer to Page 63 for the Calibration procedure.

X-ray tubes that sit dormant for several months can become electrically unstable. To remedy this condition, it is recommended you perform a “new tube seasoning procedure.” This process establishes stable high voltage operation and will ultimately extend the life of the tube. Repeat this procedure before returning to normal operation any time the system has been unused for more than two months.

1. Verify system operation.
2. Energize the system.
3. Select 60 kilovolts, 7 milliamperes, and the exposure time of one second.
4. Make five exposures at this level, observing the normal cooling time.
5. Select 65 kilovolts, 7 milliamperes, and the exposure time of one second.
6. Make five exposures at this level, observing the normal cooling time.
7. Select 70 kilovolts, 6 milliamperes, and the exposure time of one second.
8. Make five exposures at this level, observing the normal cooling time.

### Your responsibilities as an installer and service engineer

***Verification of machine performance after installation*** must be performed according to the guidelines identified in the “System Function Checklist” which may be found in the User Manual or, the Installation and Service Manual.

***Verification of machine performance after maintenance or repair*** must be performed according to the guidelines identified in the “System Function Checklist” and the calibration instructions which may be found in the Installation and Service Manual.

## Optional Installation Procedures

### Installing the Coil-cord Hand Switch Option (30-A2040)

#### Jumper Configuration for Coil-cord Hand Switch

The VetVision DC X-Ray System can be installed with an optional coil-cord hand switch (30-A2040). The coil-cord hand switch is used to make exposures, in addition to or replacing the use of the exposure button. Installation of the coil-cord hand switch involves connecting the hand switch into the connector on the bottom of the Operator Panel.

**Note:** The coil-cord hand switch is not included with the standard system.

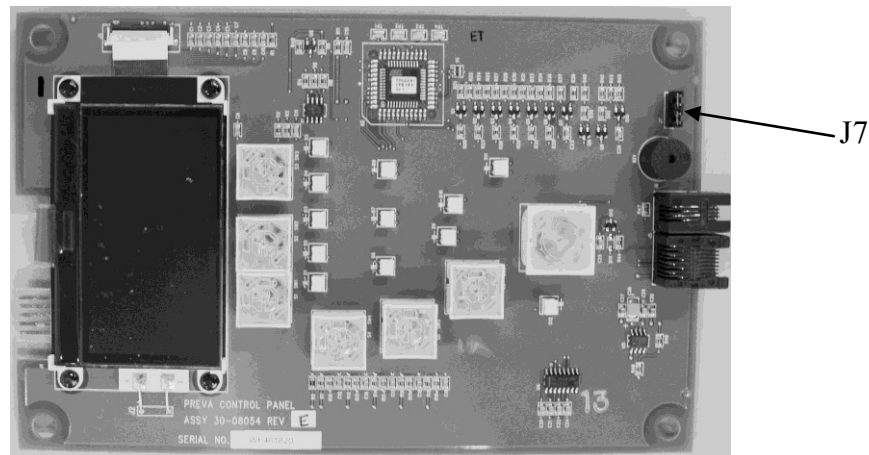
If the coil-cord hand switch is used, it may be required to disable the Exposure button on the control panel (consult your local laws). A jumper must be removed on the Operator Panel Board 30-08054, shown in Figure 34, to disable the operation of the hand switch.

1. Turn the power off.
2. Remove the Operator Panel from its mounting on the Control Unit or wall plate.
3. Unplug the cable that connects the Operator Panel to the Control Unit.
4. With a Phillips screwdriver, remove the 4 screws from the back of the Operator Panel. Put the screws in a safe location for later use.
5. Remove the back cover from the Operator Panel. Lift out the Operator Panel Board 30-08054.
6. To disable the use of the Exposure button on the Operator Panel, locate point J7 on the Operator Panel Board 30-08054. Then remove the shunt on J7.
7. Put the Operator Panel Board 30-08054 back in position.
8. Put the cover on the back of the Control Panel using the 4 screws.

#### J7 – Exposure Switch Jumper Settings

Jumper Position	Switch Closure Required for Exposure
1-2, 3-4 (default)	Remote Switch <b>or</b> Panel Switch (parallel)
2,3	Remote Switch <b>and</b> Panel Switch (series)
3,4	Remote Switch (panel switch disabled)





**Figure 34**  
Disabling the Use of  
the Exposure Button

### Connecting the Coil-cord Hand Switch— Operator Panel Located on Control Unit

1. Remove the screw holding the front cover of the Control Unit in place. Place the screw in a safe location for later use.
2. Remove the front cover.
3. Cut out the notch on the base of the Control Unit front cover.
4. Route both the Operator Panel cable and the coil-cord hand switch through the hole in the bottom of the Control Unit front cover.
5. Place a loop of the coil cord into the notch.
6. Carefully reassemble the Control Unit front cover, keeping the coil-cord in the notch. Secure the front cover with the screw that was removed in step 1.
7. Locate the Operator Panel in the top portion of the shipping carton.
8. Connect the coil-cord hand switch to the left plug socket (as viewed from the back) on the bottom of the Operator Panel. Connect the short white cable to the right plug socket.
9. Carefully dress the two cables back into the front cover of the Control Unit.
10. Snap the Operator Panel into place on the front cover of the Control Unit.
11. Mount the bracket for the coil-cord hand switch in a convenient location.
12. Stow the coil-cord hand switch.

### Connecting the Coil-cord Hand Switch— Operator Panel in Remote Location

1. Route the cable from the coil-cord hand switch through the hole in the wall mounting plate.
2. Place a loop of the coil cord into the notch.
3. Locate the Operator Panel in the top portion of the shipping carton.
4. Connect the coil-cord hand switch to the left plug socket (as viewed from the back) on the bottom of the Operator Panel. Connect the control cable to the right plug socket.
5. Carefully dress the two cables back into the wall.
6. Snap the Operator Panel into place on the wall mounting plate.
7. Mount the bracket for the coil-cord hand switch in a convenient location.
8. Stow the coil-cord hand switch.

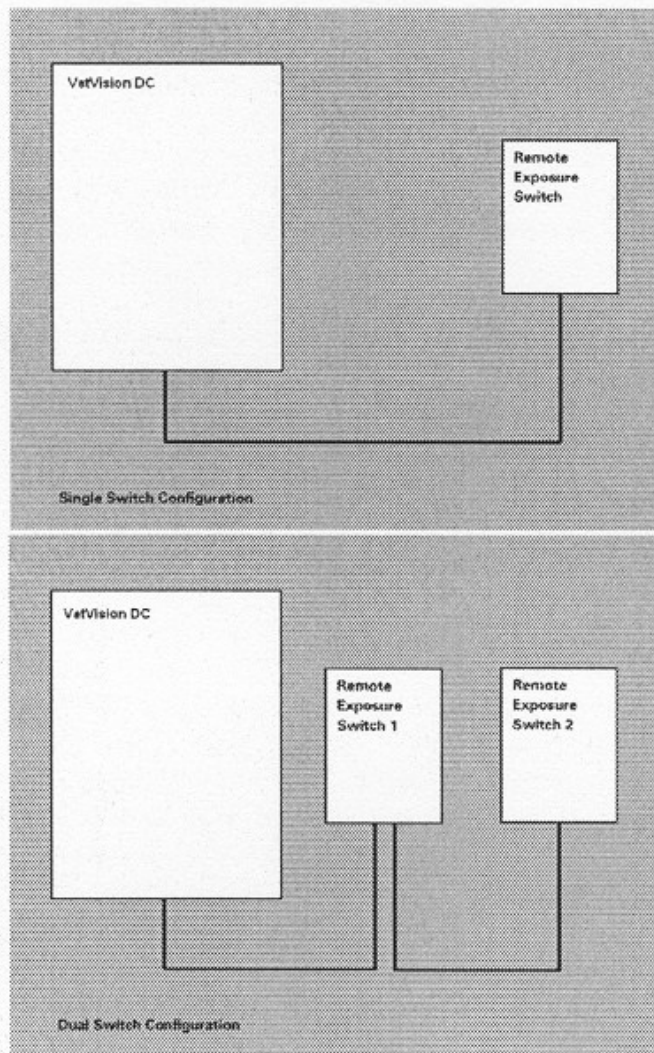
## Installing the Progeny Remote Exposure Station (30-A2044)

The Remote Exposure Station is an option for the VetVision DC that allows the operator to make the exposure from a fixed location remote from the main unit. As shown in Figure 35, a single switch can be used, or two switches can be used in series or in parallel. Two switches in series will require both switches to be pressed simultaneously to make an exposure. If two switches are used in parallel, only one needs to be pressed to make an exposure.

### Tools

The following tools are required to install the switch:

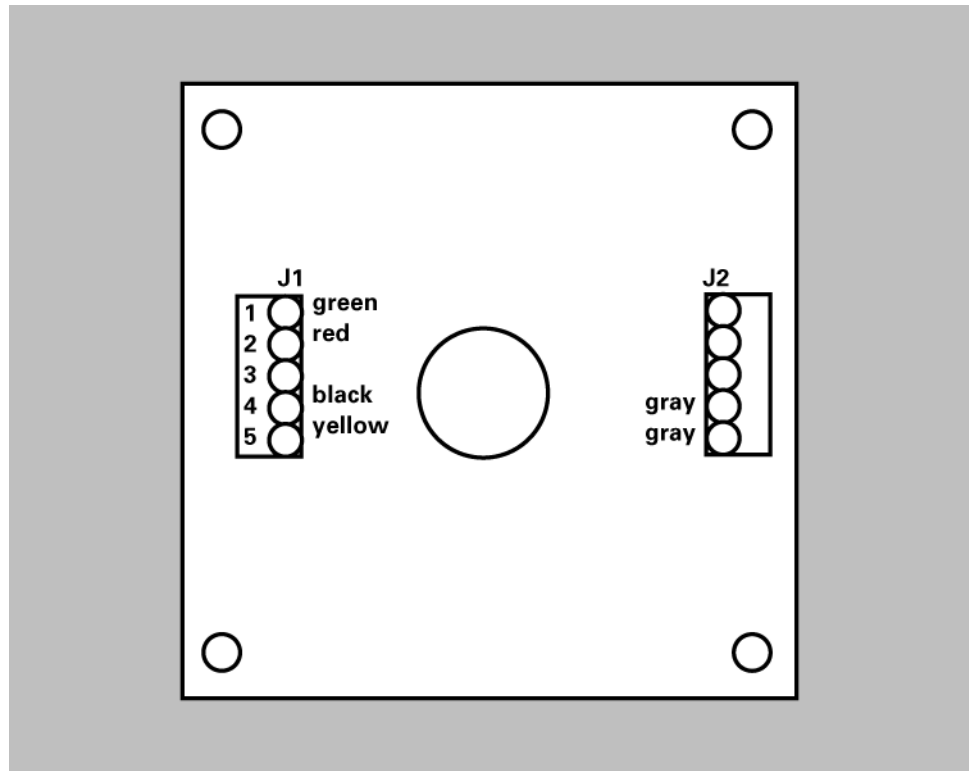
- Phillips screwdriver
- Flat-blade screwdriver
- Telephone cable stripper (for dual switch configuration only)
- Wire stripper (for dual switch configuration only)



**Figure 35**  
Remote Switch  
Configurations

## Installing the Single Switch

1. Route the cable for the Remote Exposure Switch from the VetVision DC mounting location to the Remote Exposure Switch mounting location. This can be done through conduit or on the wall surface. For either method, a 2" x 4" junction box should exist where the Remote Exposure Switch is to be mounted.
2. Thread the cable end with the handset connector through the opening in the wall mount cover from the inside and connect it to the Operator Panel. If the cable is routed on the surface of the wall, it should enter the wall mount cover through the notch on the left of the power switch.
3. Connect the cable conductors on the opposite end of the cable to terminal block J1 on the PCB in the switch enclosure as shown in Figure 36.



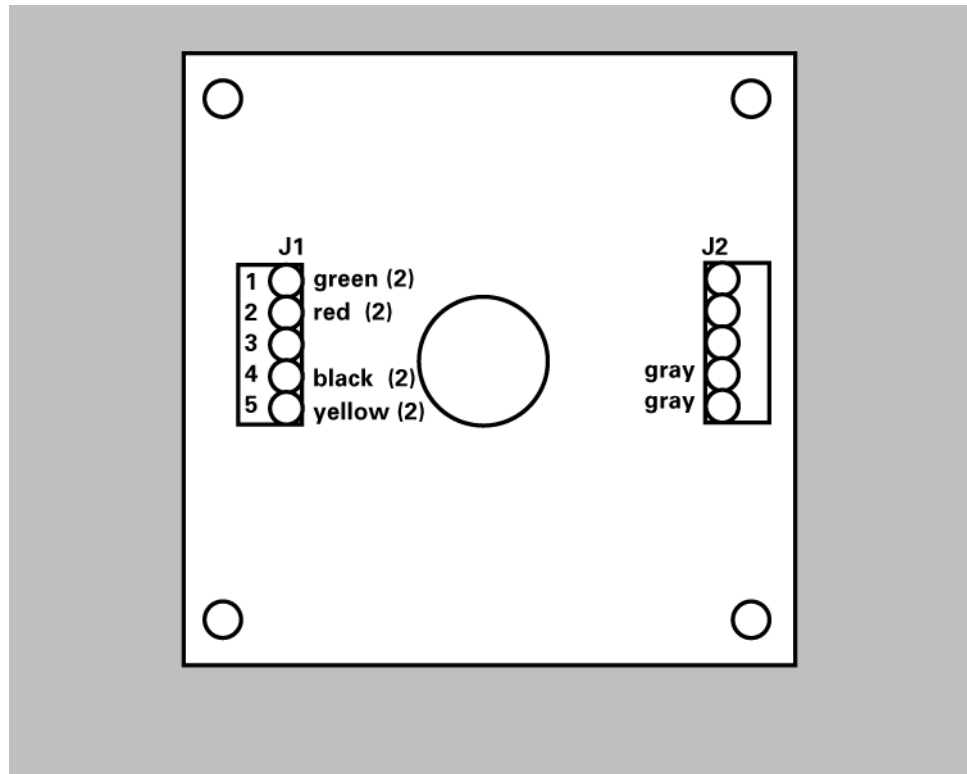
**Figure 36**  
Single Switch  
Configuration

4. Make sure the two gray wires from the pushbutton switch are connected to terminals 1 and 2 of J2.
5. Screw the inner section of the enclosure to the junction box using the two screws provided. If the cable is routed on the surface of the wall, make sure it sits in the notch on the bottom of the enclosure. Confirm that no wires are being pinched between the junction box and the enclosure.
6. Hook the outer section of the enclosure and fasten the two pieces at the bottom with the 6-32 x 5/16" screw.

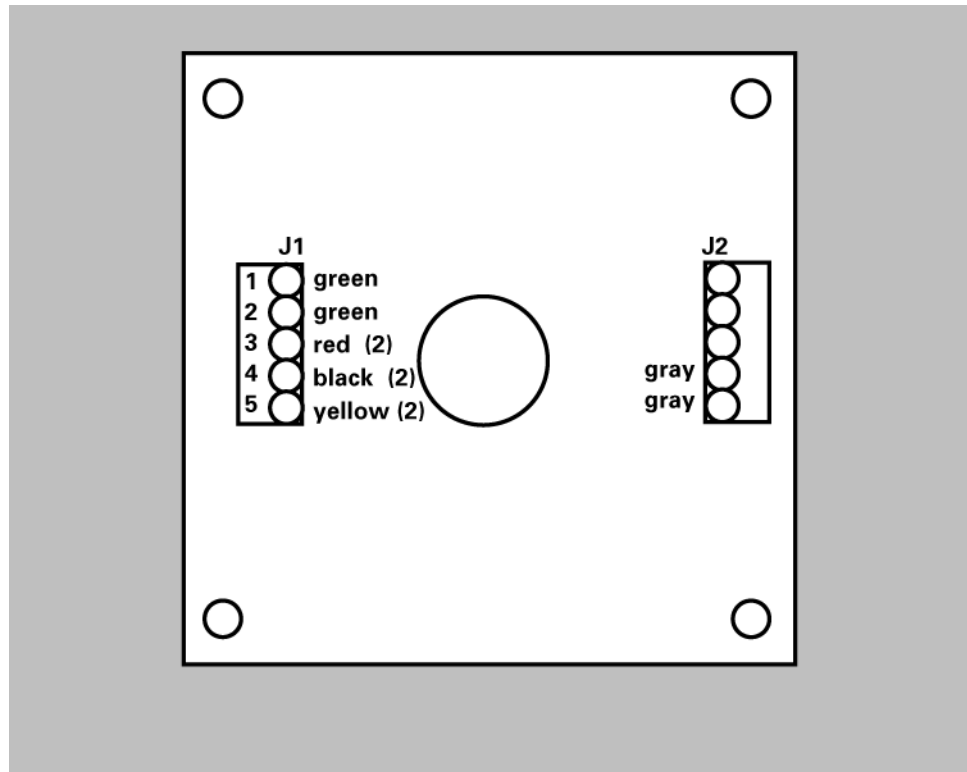
## Installing the Dual Switch

**Note:** This configuration uses two cables. One connects the VetVision DC to the first switch and the other connects the first switch to the second switch.

1. Route one cable from the VetVision DC to the first switch location either through conduit or on the surface of the wall.
2. Route the other cable from the first switch location to the second switch location either through conduit or on the surface of the wall.
3. Thread the first cable end with the handset connector through the opening in the wall mount cover from the inside and connect it to the Operator Panel. If the cable is routed on the surface of the wall, it should enter the wall mount cover through the notch on the left of the power switch.
4. For a parallel connection, connect the cable conductors of both cables to terminal block J1 on the PCB of switch enclosures #1 as shown in Figure 37. The (2) indicates that two green wires will join together in terminal 1 of J1, etc. For a series connection, connect the wires as shown in Figure 38.



**Figure 37**  
Parallel Switch  
Configuration

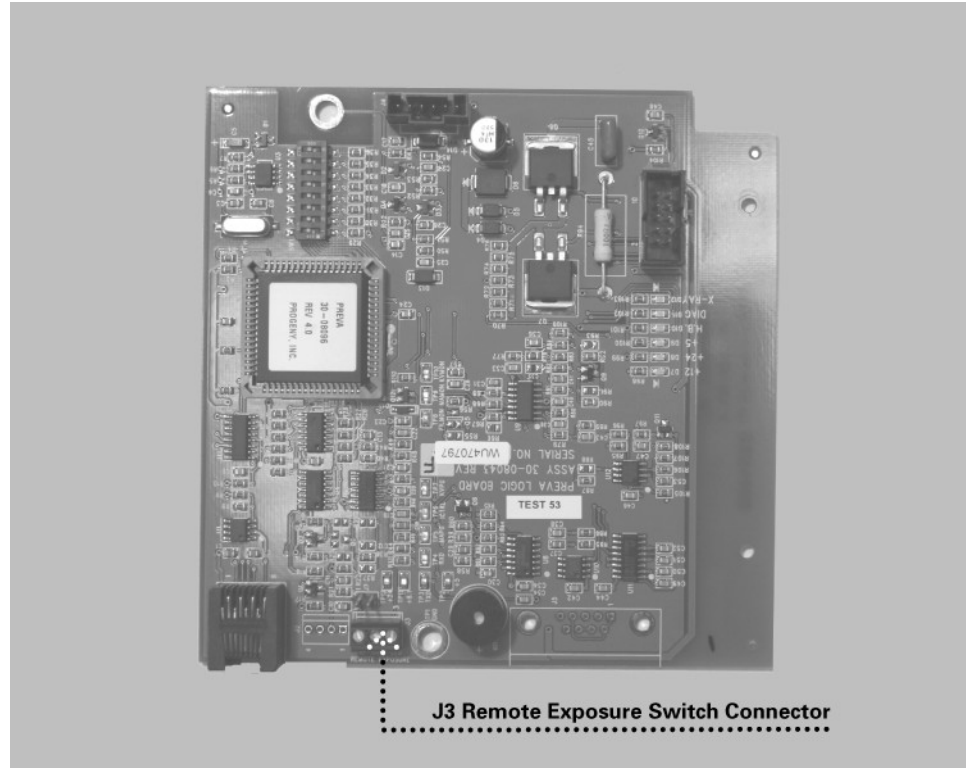


**Figure 38**  
Series Switch  
Configuration

5. Make sure the two gray wires from the pushbutton switch are connected to terminals 1 and 2 of J2.
6. Screw the inner section of enclosure #1 to the junction box using the two screws provided. If the cable is routed on the surface of the wall, make sure it sits in the notch on the bottom of the enclosure. Confirm that no wires are being pinched between the junction box and the enclosure.
7. Hook the outer section of the enclosure onto the inner section at the top. Push the wires all the way into the enclosure and fasten the two pieces at the bottom with the 6-32 x 5/16-inch screw.
8. Cut the handset connector from the end of the cable that will connect to switch enclosure #2 and strip about 1 ½-inch of the white jacket.
9. Strip ¼-inch of insulation from each of the conductors.
10. Connect the cable conductors to terminal block J1 on the PCB of switch enclosure #2 as shown in Figure 36(the same as the single switch configuration).
11. Make sure the two gray wires from the pushbutton switch are connected to terminals 1 and 2 of J2.
12. Screw the inner section of enclosure #2 to the junction box using the two screws provided. If the cable is routed on the surface of the wall, make sure it sits in the notch on the bottom of the enclosure. Confirm that no wires are being pinched between the junction box and the enclosure.
13. Hook the outer section of the enclosure onto the inner section at the top. Push the wires all the way into the enclosure and fasten the two pieces at the bottom with the 6-32 x 5/16-inch screw.

## Connecting to a Generic 2 Wire Remote Exposure Switch

To use a generic 2-wire switch, connect the wires to the terminal block J3 Remote Exposure Switch Connector on the Power Supply Control Board 30-08043, as shown in Figure 39.



**Figure 39**  
Installing the  
Remote Exposure  
Switch

## Installing the 12 Inch Cone (30-A2033)

The VetVision DC X-Ray System is factory set for use with the standard supplied 8 inch (20 cm) Cone. The 12 inch (30 cm) Cone (30-A2033) is recommended when using parallel film positioning techniques. Using the longer cone requires longer exposure times. See the System Configuration section of this manual for setting the system to use the longer cone.

# System Configuration

## System Configuration Mode

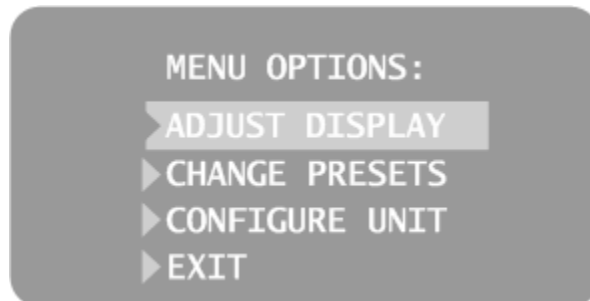
### About System Configuration Mode

The VetVision DC X-Ray System has a software-driven system configuration mode. When the VetVision DC is in system configuration mode, you can perform the following procedures:

- Adjusting the Display
- Changing Pre-programmed Exposure Settings
- Changing the Cone Size
- Showing Current System Configuration
- Displaying Diagnostic Data

### Using System Configuration Mode

1. To enter system configuration mode, press the Tooth Selection and Patient Size Selection buttons on the Operator Panel simultaneously for 5 seconds. The display shows the Main System Configuration menu, as shown in Figure 40, and the Ready Indicator blinks.
2. To select menu items while in system configuration mode, use the up and down arrows to highlight a menu option. Then use the right arrow button as an “Enter” button to select the highlighted option. When changing presets, the right arrow button is also used to select the technique factor.
3. After selecting a menu option, use the up and down arrows to increase or decrease values.



**Figure 40**  
Main System Configuration Menu

## Adjusting the Display

### Adjusting Contrast

### Reversing the Image

The VetVision DC X-Ray System allows the operator to adjust the display image.

1. From the Main System Configuration menu, Figure 40, select ADJUST DISPLAY. You will see the Display Options menu shown in Figure 41.
2. Selecting EXIT returns the display to the Main System Configuration menu.
  1. Select ADJUST CONTRAST from the menu. You will see the Progeny logo.
  2. Use the up and down arrows to increase or decrease the contrast between the menu text and the display background.
  3. Press the right arrow to save your settings.
1. Select REVERSE IMAGE from the menu. The text and display background colors will be swapped.
  2. Press the right arrow to save your settings.



**Figure 41**  
Display Options  
Menu



## Changing Pre-programmed Exposure Settings

The VetVision DC X-Ray System allows the operator to increase or decrease image density for all presets for a receptor simultaneously or to change each of the technique factors for a preset individually. You can also restore factory default settings. For charts of the factory default settings, refer to Factory Default Exposure Settings later in this manual.

**Note:** If the 12 inch cone is going to be used, configure the VetVision DC for use with the 12 inch cone before changing pre-programmed exposure settings. Configuring the VetVision DC for use with the 12 inch cone will reset exposure settings to the default settings used with the 12 inch cone.

### Displaying the Change Presets Menu

1. From the Main System Configuration menu, Figure 40, select CHANGE PRESETS. You will see the Preset Options menu shown in Figure 42.
2. Selecting EXIT returns the display to the Main System Configuration menu.

### Changing All Receptor Settings Globally

1. Select ALTER DENSITIES from the Preset Options menu. The first Image Receptor Type illuminates. The display shows the selected Image Receptor Type and current density.
2. Using the Image Receptor Type button, select the image receptor to adjust.
3. Use the up and down arrow buttons to specify a percentage by which densities will be increased or decreased for the selected receptor. Densities can be increased in steps of 25% and decreased in steps of 20%.
4. Press the right arrow to save your settings.

### Preprogramming to Digital Sensors

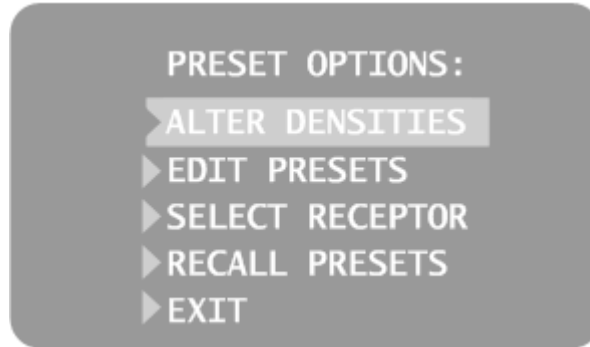
1. Energize the system.
2. Press the Tooth Selection and Patient Size Selection buttons for five full seconds.
3. Select CHANGE PRESETS from the Menu Options screen.
4. Select SELECT RECEPTOR from the Preset Options menu.
5. Press the up or down button to highlight the sensor or phosphor plate to change, and press Enter.
6. Select YES or NO on the Verification screen.
7. Exit the Preset Options menu.

### Changing Presets Individually

1. Select EDIT PRESETS from the Preset Options menu. The display notifies you that you are entering Edit Preset Mode, and Tooth Size, Image Receptor Type and Patient Size are illuminated.
2. Use the Tooth Selection, Image Receptor Type and Patient Size Selection buttons to select the preset to change. The display shows the current values for the preset.
3. Use the right arrow button to display the technique factor to change.
4. Use the up and down arrow buttons to set the value for the selected technique factor and preset.
5. Repeat steps 2-4 to change additional presets.
6. When you have completed all changes, press the Tooth Selection and Patient Size Selection buttons simultaneously for 5 seconds to record the change.

## Recall Presets

1. To return all presets to factory defaults, select RECALL PRESETS from the Preset Options menu. The menu will ask you to confirm your choice.
2. Select YES using the up arrow button and return all presets to factory default settings. Selecting YES will erase any custom presets that have been set up.
3. Select NO using the down arrow button and retain current presets.

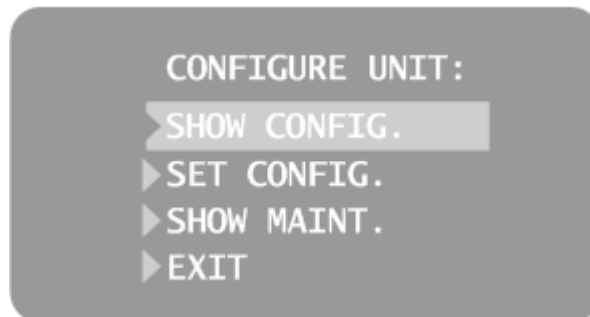


**Figure 42**  
Preset Options  
Menu

## Showing Current System Configuration

The VetVision DC X-Ray System displays the current system configuration. This display is informational only.

1. From the Main System Configuration menu, Figure 40, select CONFIGURE UNIT. You will see the Configuration menu shown in Figure 43.
2. Select SHOW CONFIG. The display will show:
  - Current software version
  - Cone size
  - Diagnostic mode on or off
3. Press any button on the Operator Panel to return to the Configuration menu.



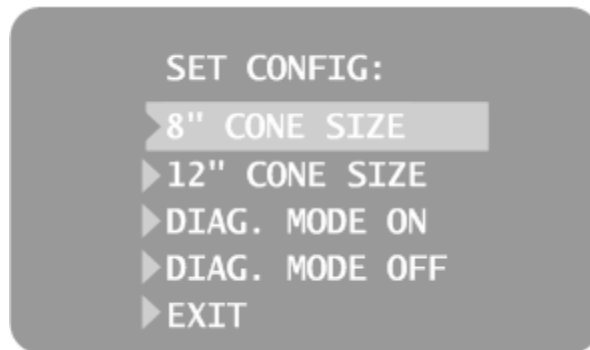
**Figure 43**  
Configuration Menu

## Changing the Cone Size

### Using a 12 inch Cone

Selecting SET CONFIG. from the Configuration menu, Figure 43, displays the Set Configuration menu, Figure 44, with options to change the cone size. The VetVision DC X-Ray System is factory set for use with the standard supplied 8 inch (20 cm) Cone. The 12 inch (30 cm) Cone (30-A2033) is available. Using the longer Cone requires longer exposure times, which the VetVision DC automatically selects when you change the Cone size in the Set Configuration menu.

1. From the Main System Configuration menu, Figure 40, select CONFIGURE UNIT. You will see the Configuration menu shown in Figure 43.
2. Select SET CONFIG. You will see the Set Configuration menu, shown in Figure 44.
3. From the Set Configuration menu, use the up and down arrows to highlight the 12" CONE SIZE.
4. Press the right arrow button to select the 12 inch Cone. The display warns you that selecting the 12 inch Cone will override custom presets with the default factory settings for the 12 inch Cone.
5. Using the up arrow, select YES to install presets for the 12 inch Cone.



**Figure 44**  
Set Configuration  
Menu

## Diagnostic Mode

### About Diagnostic Mode

The VetVision DC X-Ray System has a diagnostic mode in which you can display a summary of maintenance data or display feedback values after each exposure.

### Showing the Maintenance Summary

1. From the Main System Configuration menu, Figure 40, select CONFIGURE UNIT. You will see the Configuration menu shown in Figure 43.
2. Select SET CONFIG. You will see the Set Configuration menu, shown in Figure 44.
3. To display a summary of maintenance data, highlight select SHOW MAINT. The following maintenance data are displayed:
  - Total KJ (kilojoules—total system heat on the x-ray tube)
  - Exposure Count
  - Reboots (power up cycles)
  - OT Counts (over-threshold counts)
4. Press any button on the Operator Panel to return to the Configuration menu.

### Showing Feedback Values After an Exposure

If you take an x-ray while in diagnostic mode, the display shows feedback values for that exposure. Until you exit diagnostic mode, the display will continue to show feedback values after each exposure.

1. From the Main System Configuration menu, Figure 40, select CONFIGURE UNIT. You will see the Configuration menu shown in Figure 43.
2. Select SET CONFIG. You will see the Set Configuration menu, shown in Figure 44.
3. From the Set Configuration menu, use the up and down arrows to highlight DIAG MODE ON. Press the right arrow button to turn on diagnostic mode.
4. Exit System Configuration mode by highlighting and selecting EXIT in the Configuration and Main menus.
5. Make an exposure. The display will show the following feedback values:
  - kV
  - mA
  - Filament current
6. Press any button on the Operator Panel to clear the feedback values from the display.
7. To exit diagnostic mode, press the Tooth Selection and Patient Size Selection buttons simultaneously for 5 seconds to display the Main System Configuration menu. From the Main menu, highlight and select CONFIGURE UNIT. Then highlight and select SET CONFIG. On the Set Configuration menu, highlight and select DIAG MODE OFF.

**Note:** Feedback values are approximate.

# Calibration

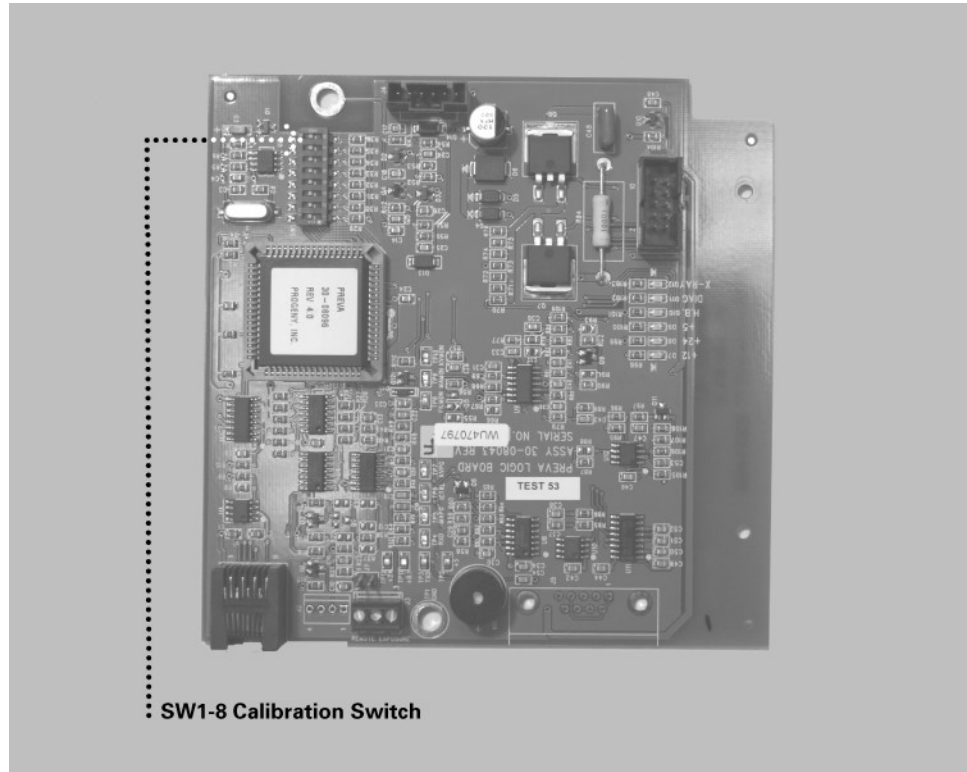
## Automated Calibration Procedure

Calibration of the VetVision DC X-Ray System is preset at the factory and is not required during initial installation. Service replacement of the Power Supply Control Board 30-08043 or the Tubehead will require calibration. The VetVision DC X-Ray System has an automated calibration function. After turning calibration on, the display instructs the technician to take a series of x-ray exposures until the unit is calibrated.

**Note:** When calibrating for the replacement of the Logic Board, the program will call for “Pre-heat” calibration. When complete, the program will move directly to “Normal” calibration mode.

1. Turn off the VetVision DC using the power switch located at the upper right of the control unit.
2. On the Power Supply Control Board 30-08043, locate SW1, as shown in Figure 45.
3. Place SW1, position 8, in the ON position.
4. Turn on the VetVision DC using the power switch located at the upper right of the control unit.
5. Press any button on the Operator Panel. The display will show the message STARTING PREHEAT CALIBRATION.
6. Press any button to begin the calibration procedure.
7. When the display asks, make an exposure. The display will show the measured results and request another exposure.
8. Continue making exposures when requested until the display shows the message CALIBRATION COMPLETE. As many as 20 or 25 exposures may be required.
9. Turn off the VetVision DC using the power switch located at the upper right of the control unit.
10. On the Power Supply Control Board 30-08043, return SW1, position 8, to the OFF position.
11. Turn on the VetVision DC using the power switch located at the upper right of the control unit.

**Note:** The “Pre-Heat Calibration Failure” error means the circuit is not detecting any feedback values from the high voltage circuit. If this error code occurs during the calibration process, inspect the condition of the feedback cable. This is the six-conductor cable passing through the tube arm assemblies starting at J4 of the Logic Board and ending at the Tubehead feed through. If this cable is okay, the error could have been caused by the Power Supply Board or the Tubehead.



**Figure 45**  
**Turning on**  
**Calibration Mode**

**Calibrating kV**

The primary calibration procedure is intended to establish proper control of tube current (mA). This is normally the only calibration required for satisfactory operation. Occasionally, it may be necessary to also calibrate kilovoltage (kV). Approximate mA and kV levels can be observed using the Diagnostic Mode feature of the VetVision DC system. If the kV needs calibration, follow these steps.

1. Energize the system.
2. Press and hold the Tooth Selector switch and the Patient Size Selector switch for five seconds.
3. Select the SET CONFIG option. You will see the Set Configuration menu, Figure 44.
4. Press the down arrow to highlight the DIAGNOSTIC MODE ON option, and press Enter. You will see the Configure Unit menu, Figure 43.
5. Press the down arrow to highlight the Exit option, and press Enter. This displays the Menu Option screen, Figure 40.
6. Press the down arrow to highlight the Exit option, and press Enter. This returns the display to operational mode.
7. Press Enter to select the kV to be adjusted.
8. Press Enter to highlight the time to be adjusted.
9. Observe normal radiation protection procedures in preparation for the following steps.
10. Make an exposure.
11. Observe the feedback values.

**Adjusting kV during Calibration**

To adjust kV:

1. Press the Up switch to activate the Adjust feature. This displays the Current kV Modulation Level screen.
2. Press the Up or Down switch while observing the Counts indicator.
3. Adjust the Counts in small increments.
4. Press Enter to exit and return to operational mode.
5. Make an exposure and observe the feedback.
6. Repeat steps 1 – 5 until the desired kV level is reached.

**Deactivating the Calibration Session**

Once completed, it is necessary to deactivate the calibration session.

1. Press and hold the Tooth Selector switch and the Patient Size Selector switch for five seconds. You will see the Menu Options screen, Figure 40.
2. Press the down arrow to highlight the CONFIGURE UNIT option, and press Enter. This displays the Configure Unit menu, Figure 43.
3. Press the down arrow to highlight the Set Configuration option, and press Enter. You will see the Set Configuration menu, Figure 44.
4. Press the down arrow to highlight the Diagnostic Mode Off option, and press Enter. This displays the Configure Unit screen.
5. Press the down arrow to highlight the Exit option, and press Enter. This displays the Menu Option screen.
6. Press the down arrow to highlight the Exit option and press Enter. This returns the system to operational mode.

# Troubleshooting

## Electrical Performance Issues

### Contact Support

Questions should be directed to Progeny Technical Support:

Phone: 888-924-3800  
 Fax: 847-415-9801  
 techsupport@progenydental.com

### General Information

#### Test Equipment

Electrical measurements require specific meter test probes. Use small test clips, such as Pomona Electronics Minigrabber Test Clip Model 6248 or Radio Shack Mini-Hook Adapters catalog # 270-334, or the equivalent.

#### Replacement Parts

- |                               |          |
|-------------------------------|----------|
| • Power Supply Board          | 30-A2155 |
| • Power Supply Control Board  | 30-08043 |
| • Operator Panel Board        | 30-08054 |
| • 25 foot Communication Cable | E1-13003 |
| • 6 inch Communication Cable  | E1-13004 |
| • Line Switch                 | E1-19000 |
| • Yoke Cable                  | 30-08071 |
| • Tubehead Assembly           | 30-A1027 |
| • Ribbon Cable                | 30-08072 |

#### Note

- If you replace the Operator Panel Board 30-08054, you must re-program any customized technique factors, as explained in the System Configuration section of this manual.
- If you replace the Power Supply Control Board 30-08043 or the Tubehead, you must recalibrate the system, as explained in the Calibration section of this manual.

#### **CAUTION!**

**The VetVision DC system has the capacity to store electrical energy during operation and after the system has been turned off.**

- **The VetVision DC system will store energy for approximately three minutes after removal from power lines.**
- **Before attempting service within the system, observe the green LED “D11” of the Power Supply Board. Illumination represents the presence of stored energy.**
- **As an added safety practice, it is recommended to measure for the presence of DC voltage across TP8 and TP5 of the Power Supply Board.**



**Your responsibilities as an installer and service engineer**

**Verification of machine performance after installation** must be performed according to the guidelines identified in the “System Function Checklist” which may be found in the User Manual or, the Installation and Service Manual.

**Verification of machine performance after maintenance or repair** must be performed according to the guidelines identified in the “System Function Checklist” and the calibration instructions which may be found in the Installation and Service Manual.

**No Operator Display but Power Switch is ON**

1. On the Power Supply Board 30-08041, check for the presence of 100 to 230 volts AC at J4, the Input Power Terminal Strip, as shown in Figure 46. If power is absent, check that the VetVision DC is connected to line power.
2. On the Power Supply Board 30-08041, measure incoming power at J3, the Line Switch Connector, as shown in Figure 46. Positions 2 and 4 carry the line voltage before the Line Switch, and positions 1 and 3 carry the line voltage after the Line Switch. Voltage at the input side of the switch, but not at the output, requires replacement of the Line Switch E1-19000.
3. Inspect the condition of the communication cable between the Power Supply Control Board and the Operator Panel. Progeny includes two communication cables with each VetVision DC system. Should the installed communication cable be suspect, temporarily substitute the other cable as a test tool.
4. If the power switch is on and there is no operator display and a faint buzzing sound is also detected, check the ribbon cable installed between the Power Supply Board and the Power Supply Control Board. If the cable is not properly seated, reinsert it. If it is damaged, replace the cable.
5. On the Power Supply Control Board, observe the power supply indicator LEDs, D7 +5 volts DC, D8 +12 volts DC, and D9 +24 volts DC, as shown in Figure 47. Voltages can also be measured by using TP1, the Common Return, and checking TP2 +5 volts DC, TP11 8.1 volts DC, and TP12 +24 volts DC. If any of these indicators are not present after power is applied, next check voltages on the Power Supply Board.
6. On the Power Supply Board, use TP2, as a common test point, and check TP1 +24 volts DC and TP3 8.1 volts DC, as shown in Figure 46. Then use TP5 as the common return to check TP4 for the presence of +12 volts DC. Should any of these voltages not be present, replace the Power Supply Board. If each voltage is present, inspect the condition of the ribbon cable between the Power Supply Board and the Power Supply Control Board. If the cable is undamaged and seated properly, replace the Power Supply Control Board.
7. If the power supply voltages are present, and the ribbon cable and communication cable are found acceptable, open the Operator Panel case and measure for the presence of +5 volts DC across TP1 and TP4 of the Operator Panel Board, as shown in Figure 48. Absence of this voltage indicates the need to reconfirm the power supply voltages and communication cable. Presence of the voltage requires the replacement of the Operator Panel Board.

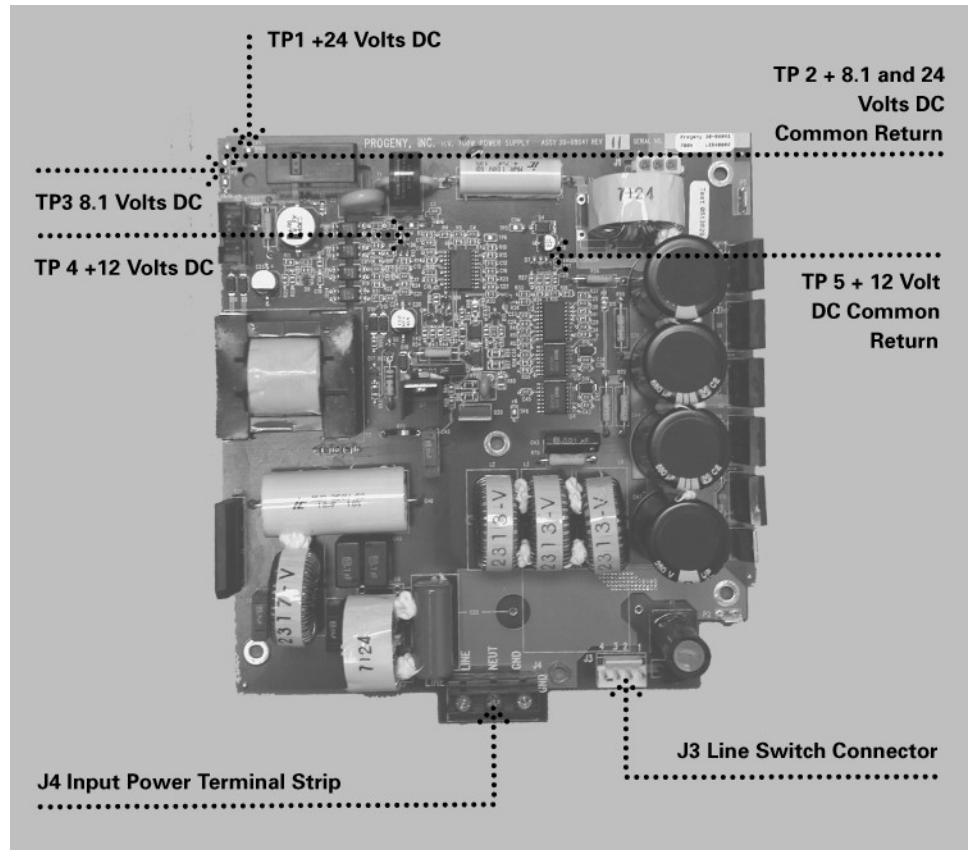


Figure 46  
Power Supply  
Board 30-08041

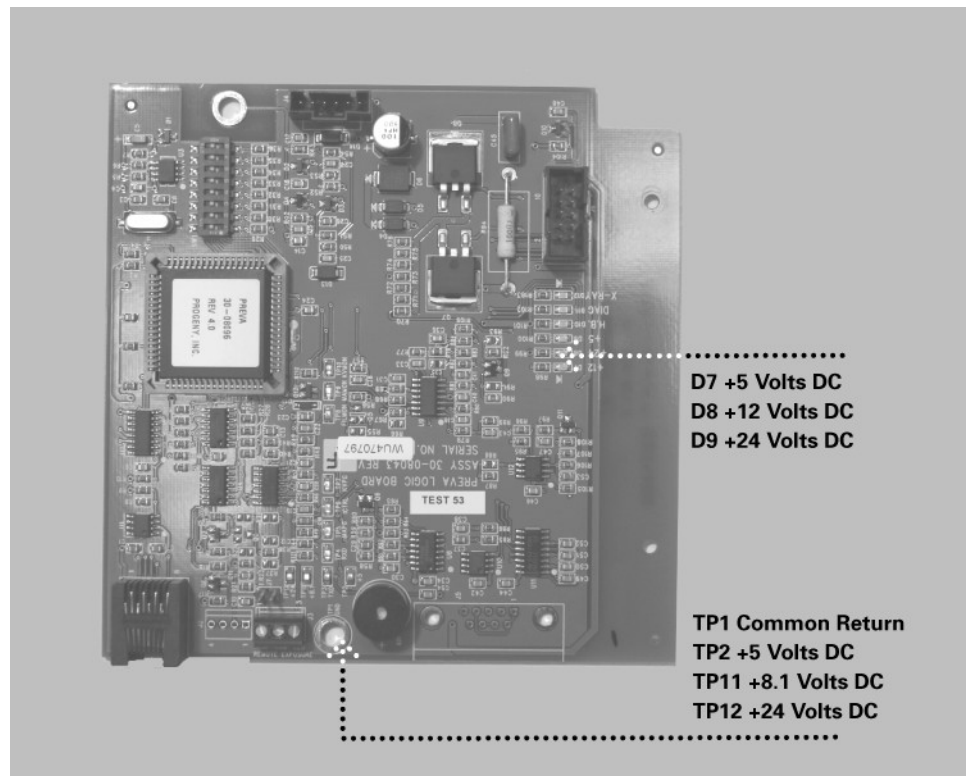


Figure 47  
Power Supply  
Control Board  
30-08043

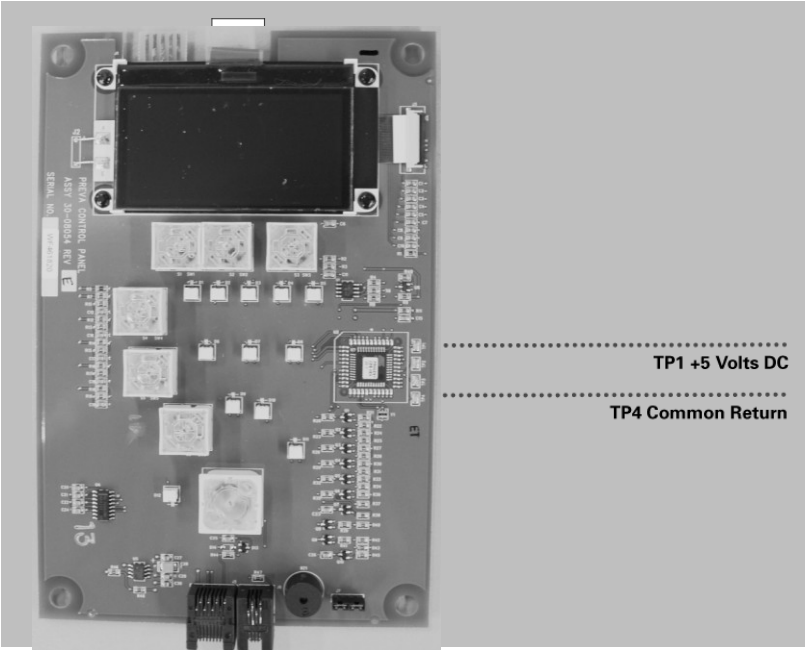


Figure 48  
Operator Panel  
Board 30-08054

**Light or Dark X-Ray Images**

1. Adjust the selected exposure time, kilovoltage or tube current to produce an acceptable image. If necessary, reprogram the techniques factors, as explained in the System Configuration section of this manual.
2. Verify the kilovoltage and tube current during an exposure using the diagnostic mode, as explained in the System Configuration section of this manual. Alternatively, you may employ a non-invasive meter to evaluate kilovoltage and exposure time.
3. Inspect the condition of the remaining imaging chain components such as the film, chemistry and processor, or the condition of the x-ray sensor and computer.
4. Check for pulsing output with fluorescent screen. If this is occurring, replace the control board.
5. Light image can be caused by the Logic Board. This is characterized by a short pulse of exposure as viewed with a fluorescent screen. Replace the Logic Board.
6. Full fluorescence with light image may require adjustment of the preprogrammed techniques.

**At Power up, the Operator Display Stops at "Progeny VetVision DC"**

Replace the operator display board.

**At Power Up, Continuous Beep, Backlit Display, No Display Characters, No Ready Light, Power Supplies OK**

Replace the Operator Display Board or the Power Supply Control Board, or both.

**At Power Up, Continuous Beep with Normal Display**

Replace the Power Supply Control Board.

**At Power Up, Buzzing Noise is Heard**

Replace the Power Supply Control Board.

**X-ray Indicator, No Exposure Termination, No Radiation Produced**

1. Check if both audible indicators operate. Check the Operator Panel first, and check the Control Logic Board second.
2. If only the Operator Panel indicator works, check if diode “D2” on the Power Supply Board and “D12” on the Logic Board illuminate during the exposure request.
3. If “D2” and “D12” do not illuminate, this indicates that the “x-ray backup” conductors in the CAT 5 communication cable are open.
4. Connect a substitute communication cable to test for this condition.
5. If the symptom persists, contact Technical Support.

**Display Shows “Error – Serial Communications”**

If the ribbon cable is open between the Logic and Power Supply Boards, replace the cable.

**Display Shows “Pre-termination Error”, Early Exposure Release Determined Not to be the Cause**

This error can be caused by a high voltage breakdown in the head and is characterized by a snapping or popping noise within the Tubehead.

1. Inspect the condition of the feedback cable.
2. Inspect the condition of the communication cable.
3. If used, inspect the remote exposure switch wiring for a loose connection.
4. Refer to the High Voltage Breakdown information in the Troubleshooting section for detailed instructions.

**All X-Ray Indicators, But No Voltage Measured at J1 on the Power Supply Board**

Replace the Power Supply Board.

**Very Short Exposures, Regardless of Selected Exposure Time**

This condition will exist if the kV or mA produced is out of tolerance. To address this issue:

1. Inspect the condition of the high voltage circuit by operating the Preva in the diagnostic mode. Confirm incorrect kV or mA.
2. Inspect the Preva's internal horizontal and articulated arm wiring. Repair as necessary.
3. If wiring is intact, and the firmware revision is 5.0 or less, attempt system recalibration. If greater, replace logic PCB assy.
4. If calibration cannot be achieved, the problem may require replacement of the tubehead assembly. Contact Progeny technical support for further assistance.
5. Check if D11 "DIAG" LED (Logic Board) is on. If so, check that DIP Switch #3 (SW1, Logic Board) is in the correct position for the brand of x-ray tube in the unit. The label on the tube head will indicate either Toshiba or Kailong. DIP Switch #3 should be in the ON position for Toshiba, Off for Kailong.

**No X-Ray Produced but Exposure Indicators Detected**

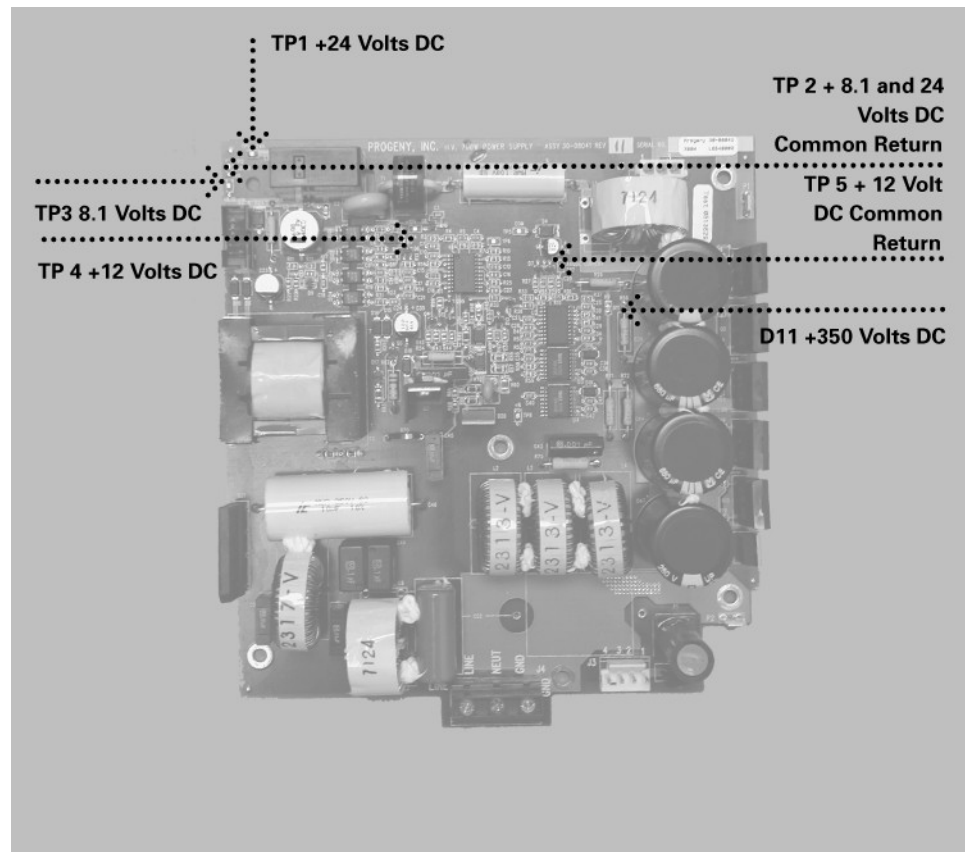
When no x-ray is produced, the VetVision DC may still operate the exposure indicators. The procedure to troubleshoot a no x-ray condition depends on which exposure indicators are detected.

1. Activate diagnostic mode, as explained in the System Configuration section of this manual.
2. Take an exposure.
3. Follow the appropriate procedure below:
  - If no kV is produced, go to the procedure "No kV Produced".
  - If no mA is produced, go to the procedure "No mA Produced".
  - If no "I" is produced, go to the procedure "No (I) Filament Produced".

**No kV Produced**

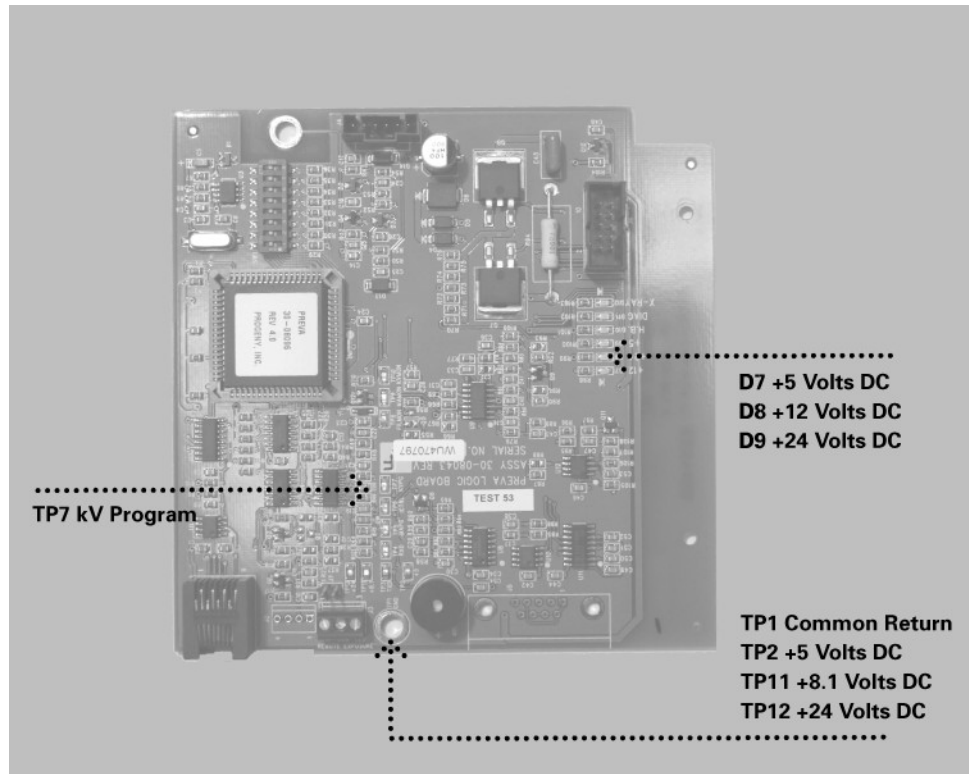
1. On the Power Supply Board, observe that the power supply indicator D11 +350volts DC is illuminated, as shown in Figure 49. Illumination represents proper stored energy for an exposure. If this indicator is not illuminated, it will be necessary to replace this board.
2. On the Power Supply Control Board, observe the power supply indicator LEDs, D7 +5 volts DC, D8 +12 volts DC, and D9 +24 volts DC, as shown in Figure 50. Voltages can also be measured by using TP1, the Common Return, and checking TP2 +5 volts DC, TP11 8.1 volts DC, and TP12 +24 volts DC. If any of these indicators are not present after power is applied, next check voltages on the Power Supply Board.
3. On the Power Supply Board, use TP2 as a common test point to check TP1 +24 volts DC and TP3 8.1 volts DC. Then use TP5 as the common return to check TP4 for the presence of +12 volts DC, as shown in Figure 49. Should any of these voltages not be present, replace the Power Supply Board. If each voltage is present, check other voltages on the Power Supply Control Board.
4. On the Power Supply Control Board, measure between TP1, the Common Return and, TP7, kV Program. This voltage should be between 3 and 4 volts DC. If this voltage is not present, replace the Power Supply Control Board. If this voltage is correct, inspect the condition of the ribbon cable between the Power Supply Board and the Power Supply Control Board. If the cable is undamaged and seated properly, replace the Power Supply Control Board.
5. Check the condition of the cables between the Control and the Tubehead assembly. If no x-ray occurs and no errors are displayed, the problem may lie within the conductors of the white connector (which is primary power to the Tubehead Assembly). If no x-ray occurs and the attempt is accompanied by a "snap" sound, the problem may lie with the conductors of the black connector (which is transmitting the feedback signals). Connections for this cable begin

- with controls at J1 of the Power Supply Board and J4 of the Power Supply Control Board. As shown in Figure 51, an internal set of connections will be accessed below the distal side of the horizontal arm and at the inside top of the Tubehead Yoke. The final set of connections is accessed by removing the Pivot Cap located at the attachment point of the Tubehead to the Yoke.
6. If D11 on the Power Supply Board is illuminated, power supplies are in order, and the cable connections are correct, place an AC voltmeter across the Tubehead connector J1 (white connector) on the black and white conductors, request an exposure time of at least 1.5 seconds, and measure the resulting voltage during the exposure. Presence of 130 volts AC will require the replacement of the Tubehead Assembly. Absence of 130 volts AC will require re-inspection of the interconnect cables for open conductors.

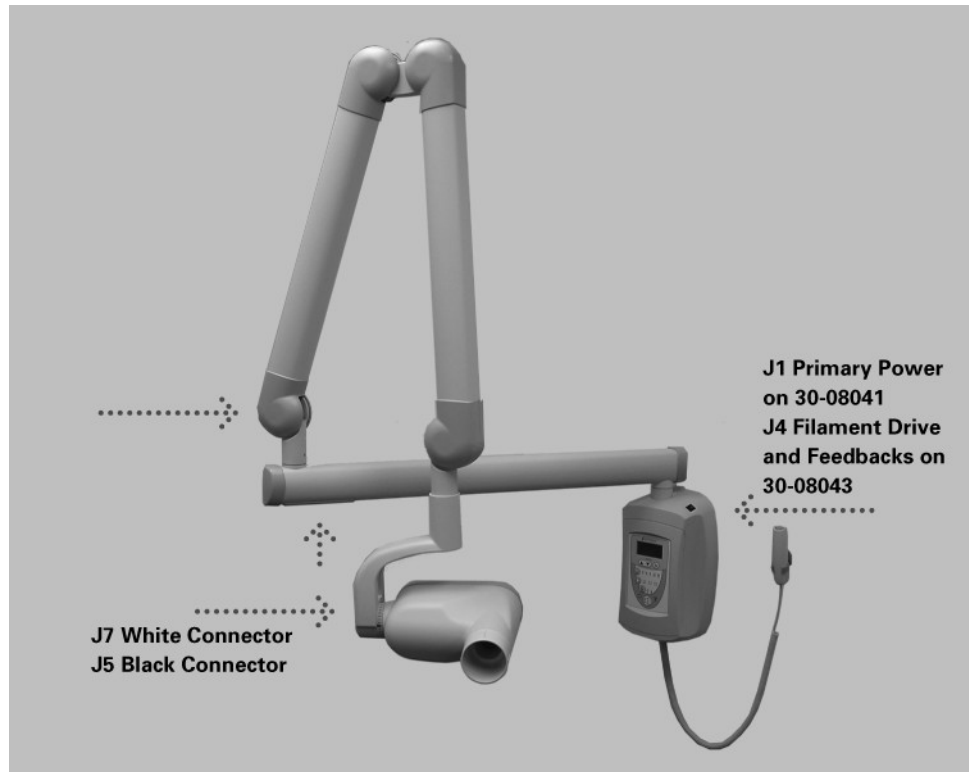


**Figure 49**  
**Power Supply**  
**Board 30-08041**

**Figure 50**  
**Power Supply**  
**Control Board**  
**30-08043**



**Figure 51**  
**Interconnect Cable**  
**Locations**

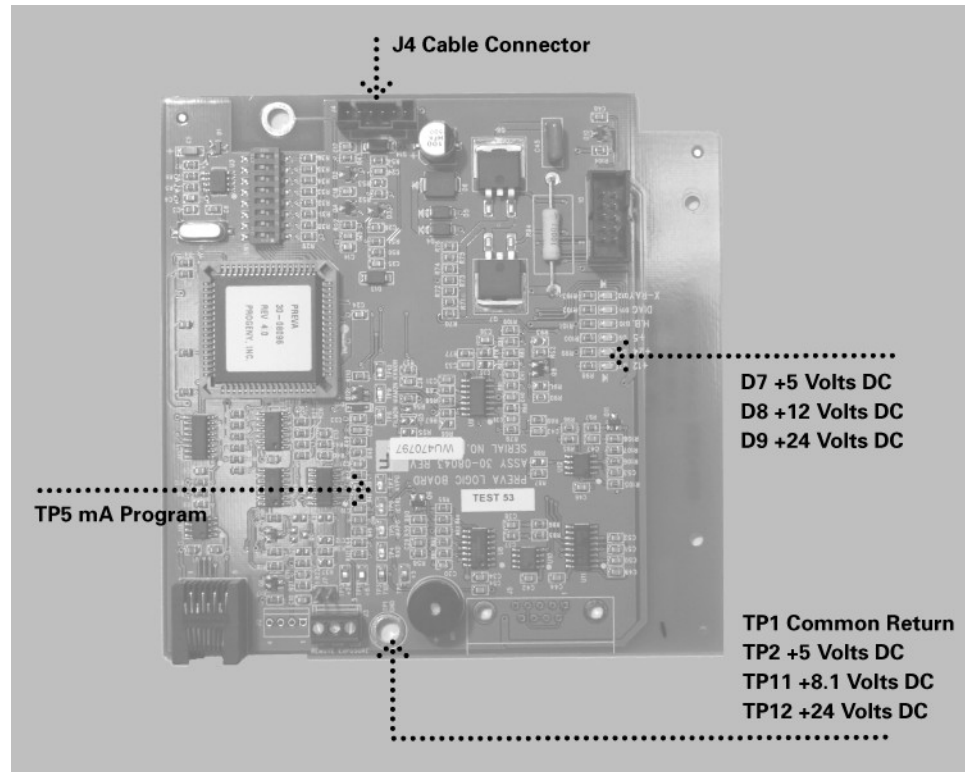




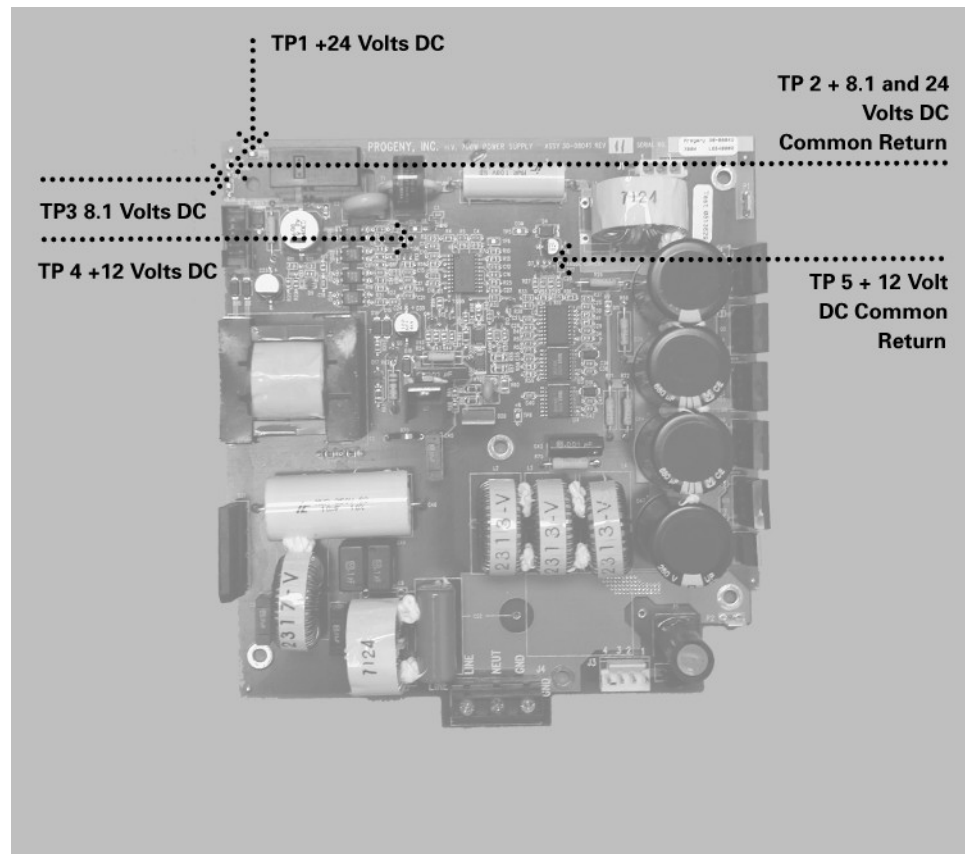
**No mA  
Produced**

1. On the Power Supply Control Board, observe the power supply indicators, D7 +5 volts DC, D8 +12 volts DC, and D9 +24 volts DC, as shown in Figure 52. Voltages can also be measured by using TP1, the Common Return, check TP2 +5 volts DC, TP11 8.1 volts DC, and TP12 +24 volts DC. If any of these indicators are not present after power is applied, check other voltages on the Power Supply Board.
2. On the Power Supply Board, use TP2 as a common test point to check TP1 +24 volts DC and TP3 8.1 volts DC. Then use TP5 as the common return to check TP4 for the presence of +12 volts DC, as shown in Figure 53. Should any of these voltages not be present, replace the Power Supply Board. If these voltages are correct, next check voltages on the Power Supply Control Board.
3. On the Power Supply Control Board, measure between TP1, the Common Return, and TP5, mA Program. This voltage should be between 1 and 2 volts DC. If this voltage is not correct, replace the Power Supply Control Board.
4. If this voltage is correct, select 1.5 seconds of exposure time, measure across pin 1 and pin 2 of the Power Supply Control Board at the connector J4. During exposures, this value should be 24 volts AC. Also measure across pin 2 and pin 3 of J4. This value should be 24 volts AC. If either voltage is missing, replace the Power Supply Control Board.
5. If these voltages are present, measure for the same values at the Tubehead Assembly at the connector J5 (black) on the blue and gray conductors and the blue and brown conductors. If the voltages are not present, inspect the inter-connect cables between the control and Tubehead Assembly. Connections for this cable begin with controls at J1 of the Power Supply Board and J4 of the Power Supply Control Board. As shown in Figure 51, an internal set of connections will be accessed below the distal side of the horizontal arm and at the inside top of the Tubehead Yoke. The final set of connections is accessed by removing the Pivot Cap located at the attachment point of the Tubehead to the Yoke.
6. If the voltages are present, replace the Tubehead Assembly.

**Figure 52**  
**Power Supply**  
**Control Board**  
**30-08043**

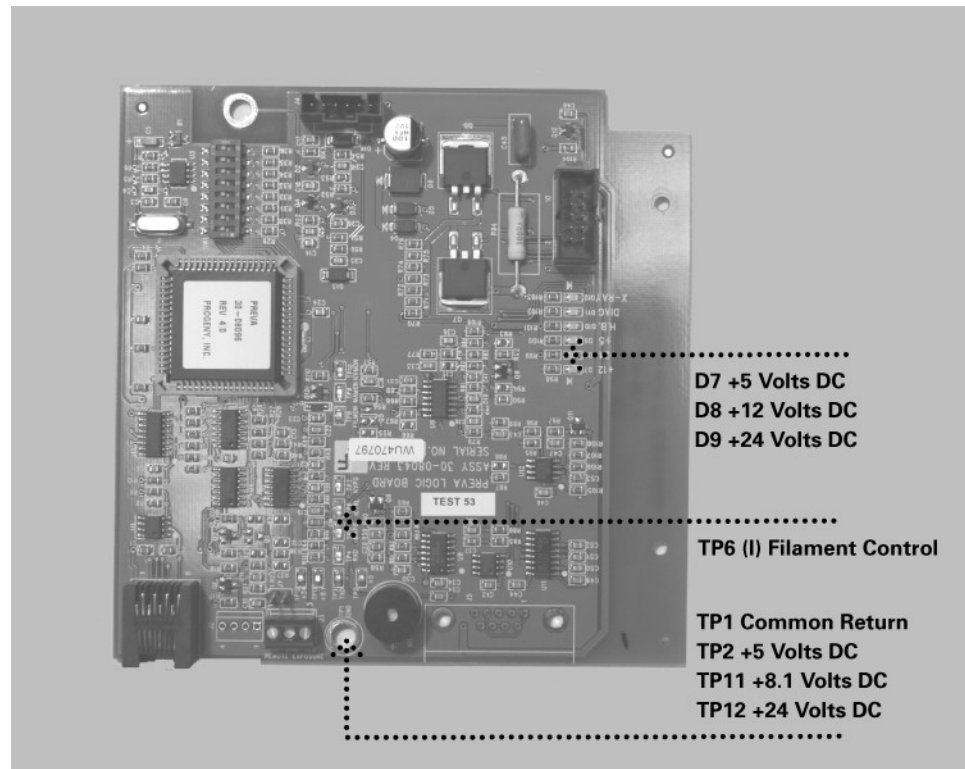


**Figure 53**  
**Power Supply**  
**Board 30-08041**

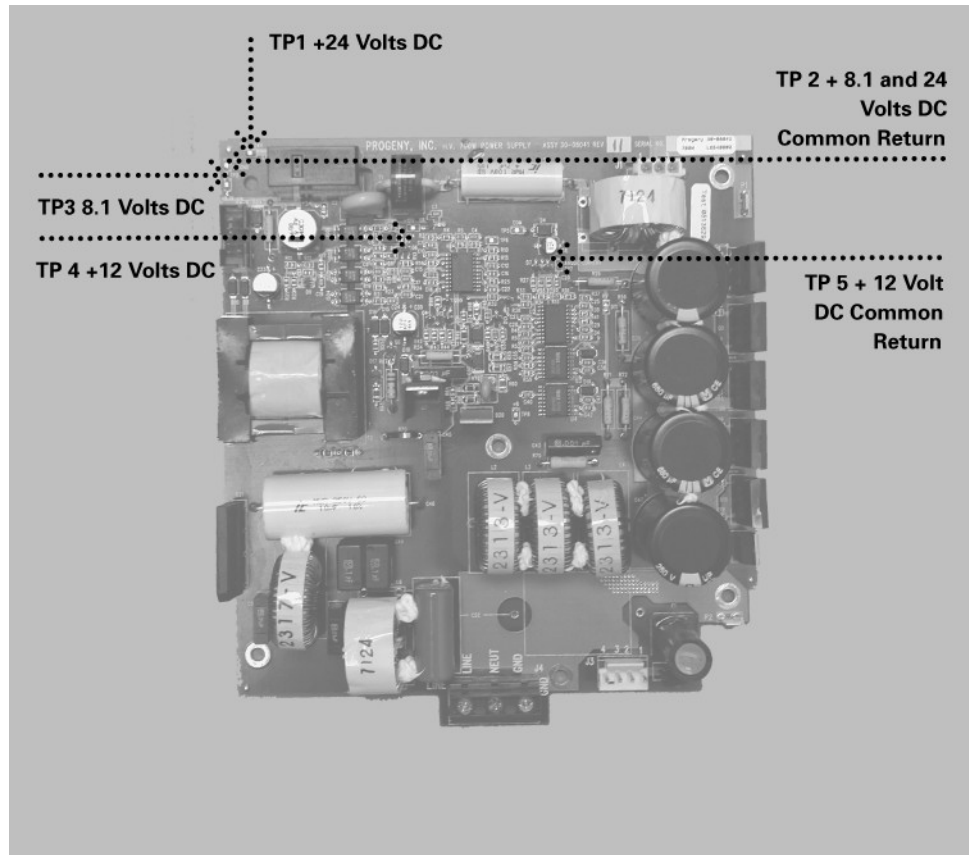


**No (I) Filament Produced**

1. On the Power Supply Control Board, observe the power supply indicator LEDs, D7 +5 volts DC, D8 +12 volts DC, and D9 +24 volts DC, as shown in Figure 54. Voltages can also be measured by using TP1, the Common Return, and checking TP2 +5 volts DC, TP11 8.1 volts DC, and TP12 +24 volts DC. If any of these indicators are not present after power is applied, next check voltages on the Power Supply Board.
2. On the Power Supply Board, use TP2 as a common test point to check TP1 +24 volts DC and TP3 8.1 volts DC. Then, use TP5 as the common return to check TP4 for the presence of +12 volts DC, as shown in Figure 55. Should any of these voltages not be present, replace the Power Supply Board. If these values are correct, check other voltages on the Power Supply Control Board.
3. On the Power Supply Control Board, measure between TP1, the Common Return and TP6, Filament Control. Select 1.5 seconds of exposure time. The measured voltage will be between 2.5 and 3 volts DC only during an exposure attempt. During the standby condition, this voltage should be zero. If this voltage is not correct, replace the Power Supply Control Board.



**Figure 54**  
**Power Supply**  
**Control Board 30-**  
**08043**

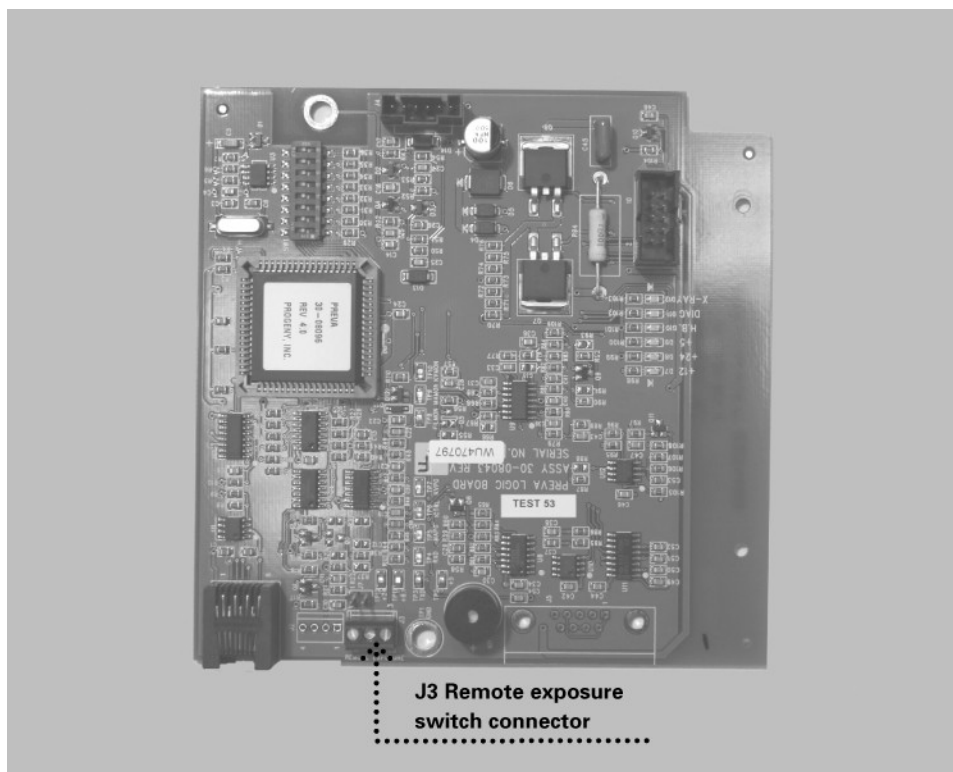


**Figure 55**  
**Power Supply**  
**Board 30-08041**

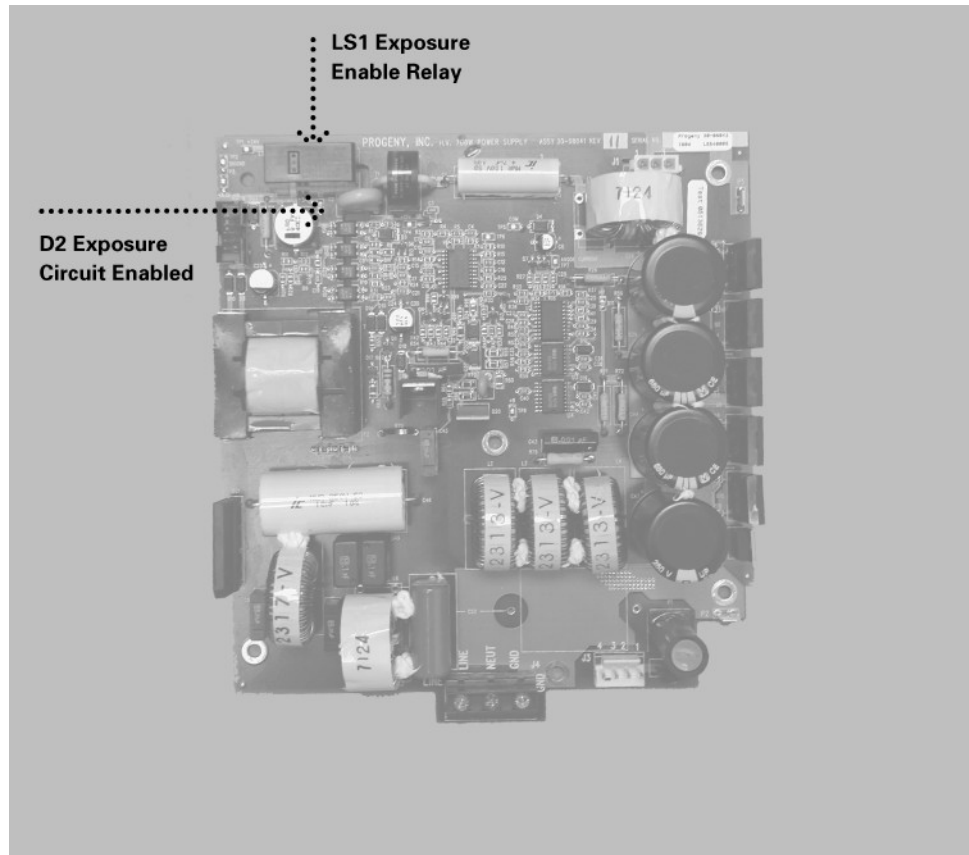
**No X-Ray Produced and No Audible Exposure Indicators**

Two different audible exposure indicators are employed within the VetVision DC system. One indicator is embedded in the Operator Panel and will initiate when any exposure switch is pressed. The second audible indicator initiates when the Power Supply Control Board begins the exposure sequence. During normal operation, first the Operator Panel indicator will sound followed shortly thereafter by the Power Supply Control indicator. It is important to recognize the sequence for troubleshooting purposes.

1. If the Operator Panel indicator does not sound, inspect the condition of any remote exposure switches. Substitution is the preferred method to test these switches, although a jumper wire can be applied across the contacts of J3, shown in Figure 56, on the Power Supply Control Board momentarily to simulate an exposure switch closure.
2. If the Operator Display indicator sounds, but the Power Supply Control Board indicator does not activate, observe LED D2 on the Power Supply Board, and listen for the relay LS1 to activate on this same board (Figure 57). LED D2 should illuminate during the exposure request. If not, inspect the condition of the ribbon cable between the Power Supply and the Power Supply Control Boards. If the ribbon cable is acceptable, replace the Power Supply Control Board.



**Figure 56**  
**Power Supply**  
**Control Board**  
**30-08043**



**Figure 57**  
**Power Supply**  
**Board 30-08041**

## High-voltage Breakdown

High-voltage breakdown is characterized by a loud snap sound during an exposure request.

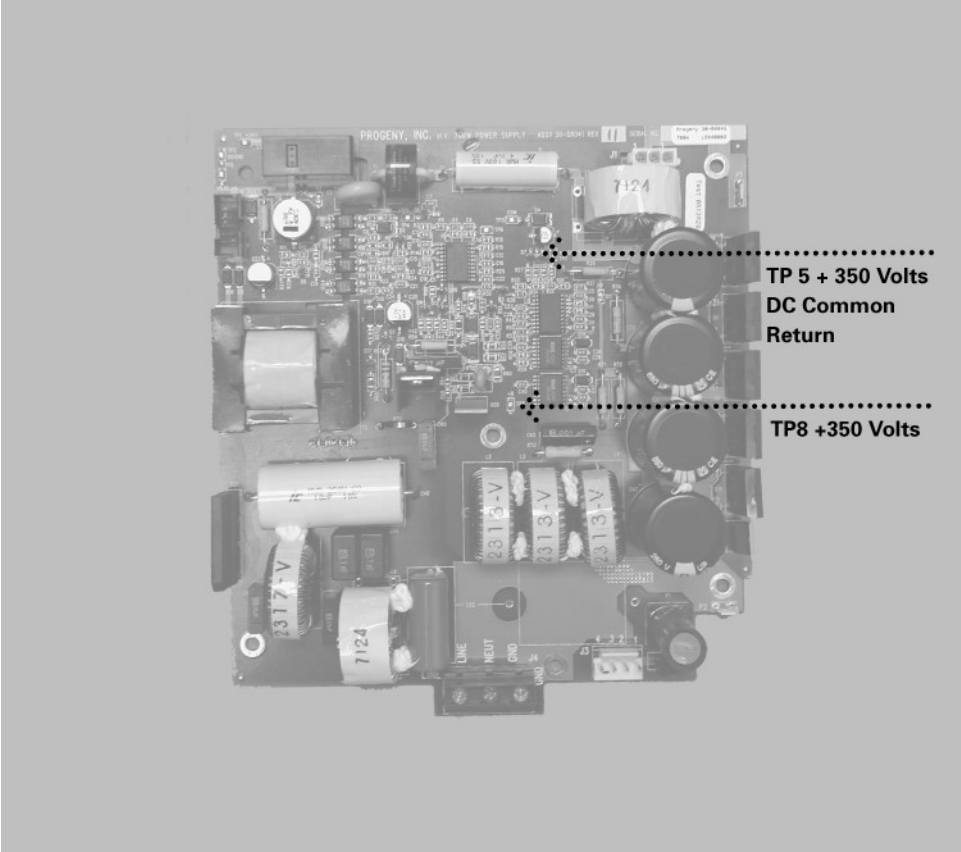
1. On the Power Supply Board, measure the voltage across TP5, the Common Return, and TP8, +350 volts DC, as shown in Figure 58. This voltage will be acceptable if measured between 330 and 390 volts DC. Values above or below this number indicate the need to replace the Power Supply Board.
2. If the voltage is correct, inspect the condition of the cabling between the Power Supply Board, Power Supply Control Board, and Tubehead Assembly.

**CAUTION!**  
**High voltage present.**

Of particular importance are the conductors held by the black connectors. These conductors transmit the feedback values from the Tubehead Assembly and directly affect the control of power to the Tubehead Assembly.

Connections for this cable begin with controls at J1 of the Power Supply Board and J4 of the Power Supply Control Board. As shown in Figure 51, an internal set of connections will be accessed below the distal side of the horizontal arm and at the inside top of the Tubehead Yoke. The final set of connections is accessed by removing the Pivot Cap located at the attachment point of the Tubehead to the Yoke.

3. If the cabling is found acceptable, select 1.5 seconds of exposure time, and placing a DC voltmeter on TP1, the Common Return on the Power Supply Control Board, measure the feedback values at TP9 mA Monitor and TP10 kV Monitor, as shown in Figure 59. Look for the following values:
  - TP9 – mA Monitor. This voltage should be between 1.5 and 3.5 volts DC during exposure attempts. The voltage should not oscillate between 1.5 and 3.5; instead the measurement should come to a specific value and stabilize. Oscillating values or absent values will indicate the need to replace the Tubehead Assembly.
  - TP10 – kV Monitor. This voltage should be between 3 and 4 volts DC during exposure attempts. The voltage should not oscillate between 3 and 4; instead the measurement should come to a specific value and stabilize. Oscillating values or absent values will indicate the need to replace the Tubehead Assembly.Absent feedback values may also indicate shorted components on the H.V. Control Board (e.g., C26 and C25 for kV feedback and C27 and C16 for mA feedback). Inspect the condition of each before making a final determination. The resistance from C25 to ground should be 24 to 26 K.R.s. See Figure 59 for the location of C25.
4. If the feedback voltages are present and stable, replace the Power Supply Control Board.



**Figure 58**  
**Power Supply**  
**Board 30-08041**



**Incorrect kV**

At times, non-invasive measurement of an otherwise fully functional system indicates that kilovoltages may be incorrect. Kilovoltage is controlled by the microprocessor and is not adjustable. The VetVision DC generates kilovoltage by first establishing a reference voltage and then comparing the feedback voltage to the reference. Follow these steps to establish proper operation of the kV controls

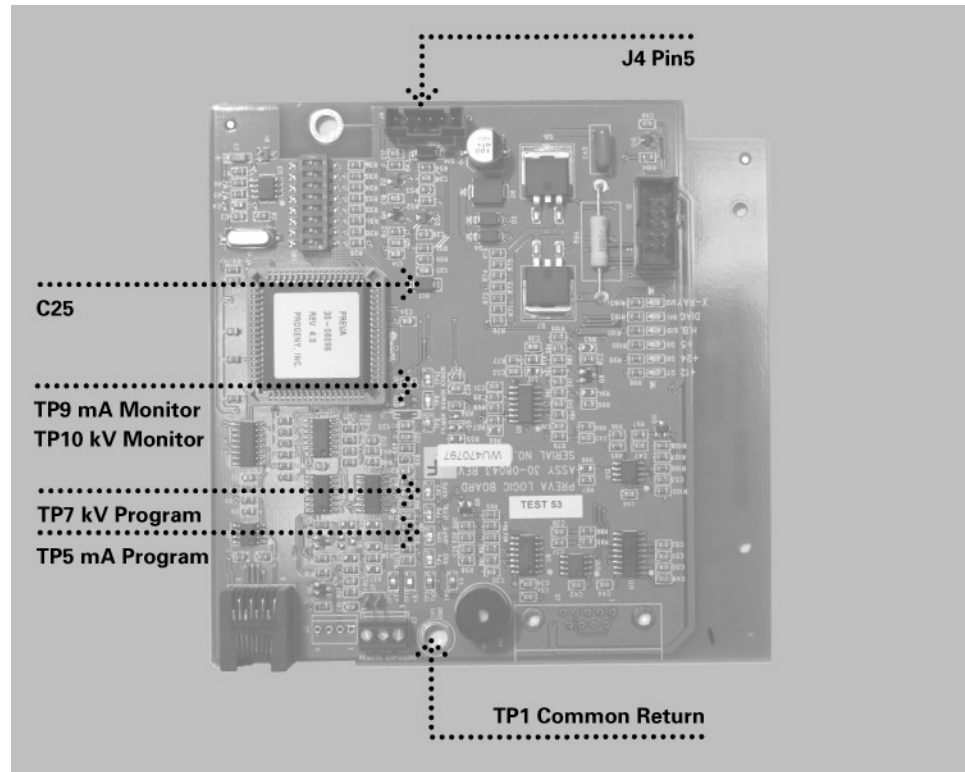
1. On the Power Supply Control Board, place a voltmeter on TP1, the Common Return, and TP7, kV Program, as shown in Figure 59. Compare measurements to the following chart (volts DC).

	<b>60 kV</b>	<b>65 kV</b>	<b>70 kV</b>
<b>4 mA</b>	3.1	3.4	3.7
<b>5 mA</b>	3.2	3.5	3.75
<b>6 mA</b>	3.3	3.8	3.8
<b>7 mA</b>	3.4	3.7	NA

2. To evaluate the feedback voltages that represent the measured kV within the system, compare the observed values in the table below. To properly observe these values, select 1.5 seconds of exposure time and measure the DC voltages during the exposure only. This measurement is made across TP1, the common return and TP10, the kV Monitor, as shown in Figure 59.

	<b>60 kV</b>	<b>65 kV</b>	<b>70 kV</b>
<b>4 mA</b>	3.1	3.4	3.7
<b>5 mA</b>	3.2	3.5	3.75
<b>6 mA</b>	3.3	3.6	3.8
<b>7 mA</b>	3.3	3.65	NA

Values that approximately match the above tables represent a correctly operating system. Other values may indicate that boards need to be replaced. Additional assistance can be obtained from Progeny Technical Support.



**Figure 59**  
**Power Supply**  
**Control Board**  
**30-08043**

**Incorrect mA**

At times, various measurements of an otherwise fully functional system indicate that milliamperage may be incorrect. Milliamperage is controlled by the microprocessor and is not adjustable. The VetVision DC generates milliamperage by first establishing a reference voltage and then comparing the feedback voltage to the reference. Follow these steps to establish proper operation of the mA controls.

1. On the Power Supply Control Board, place a voltmeter on TP1, the Common Return and TP5, mA Program, as shown in Figure 59. Compare measurements to the following chart (volts DC).

	<b>60 kV</b>	<b>65 kV</b>	<b>70 kV</b>
<b>4 mA</b>	3.1	3.4	3.7
<b>5 mA</b>	3.2	3.5	3.75
<b>6 mA</b>	3.3	3.8	3.8
<b>7 mA</b>	3.4	3.7	NA

2. To evaluate the feedback voltages which represent the measured mA within the system, refer to the table below; select 1.5 seconds of exposure time and measure the DC voltages during the exposure only. This measurement is made across TP1, the Common Return, and TP9, the mA Monitor, as shown in Figure 59.

	<b>Volts DC</b>
<b>4 mA</b>	2
<b>5 mA</b>	2.4
<b>6 mA</b>	2.9
<b>7 mA</b>	3.4

Values which approximately match the above tables represent a correctly operating system. Other values may indicate that boards need to be replaced. Further assistance can be obtained from Progeny Technical Support.

**Obtaining Technical Support**

**Contact**

PROGENY DENTAL  
 675 Heathrow Dr.  
 Lincolnshire, IL 60069  
 Phone: 888-924-3800  
 Fax: 847-415-9810  
 techsupport@progenydental.com

## Maintenance

### VetVision DC Tubehead Removal Instructions

#### Tools Required

Progeny-provided spanner wrench 30-T0055 (to be returned to Progeny)  
#1 Phillips screwdriver  
Flat blade screwdriver or pocket knife  
Needle-nose pliers  
Cable tie  
Standard 3/8" ratchet  
3/8" ratchet extension  
Foam insert



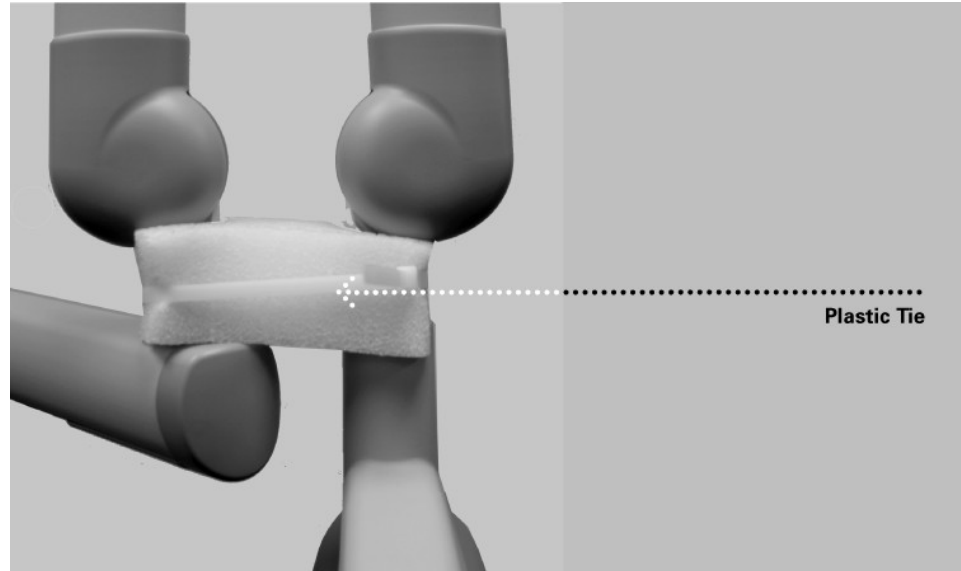
**Figure 60**  
**Tubehead**  
**Replacement Parts**

**Instructions**

1. Using the cable tie, restrain the articulating arm together as shown in Figure 61.

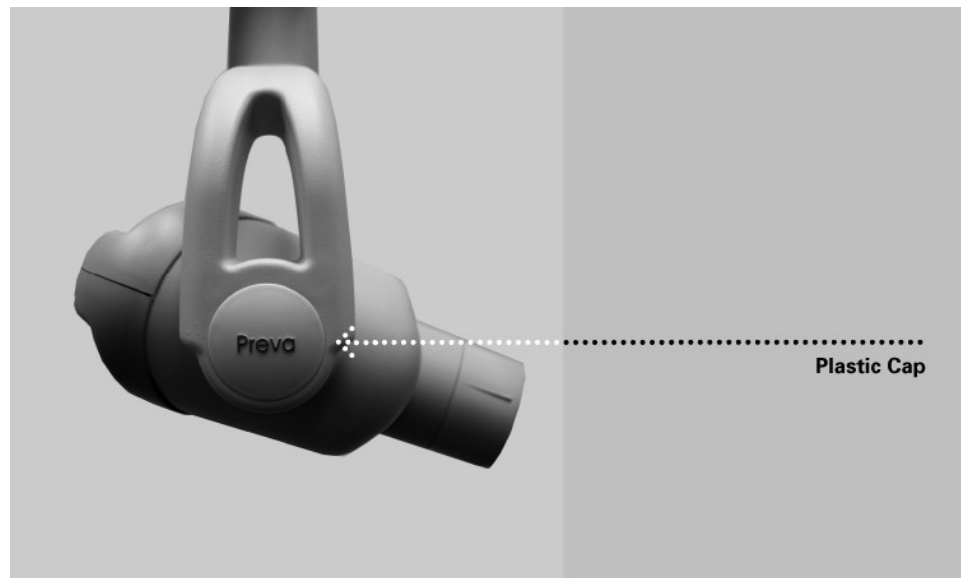
**CAUTION!**  
Failure to lock the arm in place may cause rapid movement or injury.

**Figure 61**  
Stabilizing the  
Articulating Arm  
with the Foam Insert  
and Cable Tie



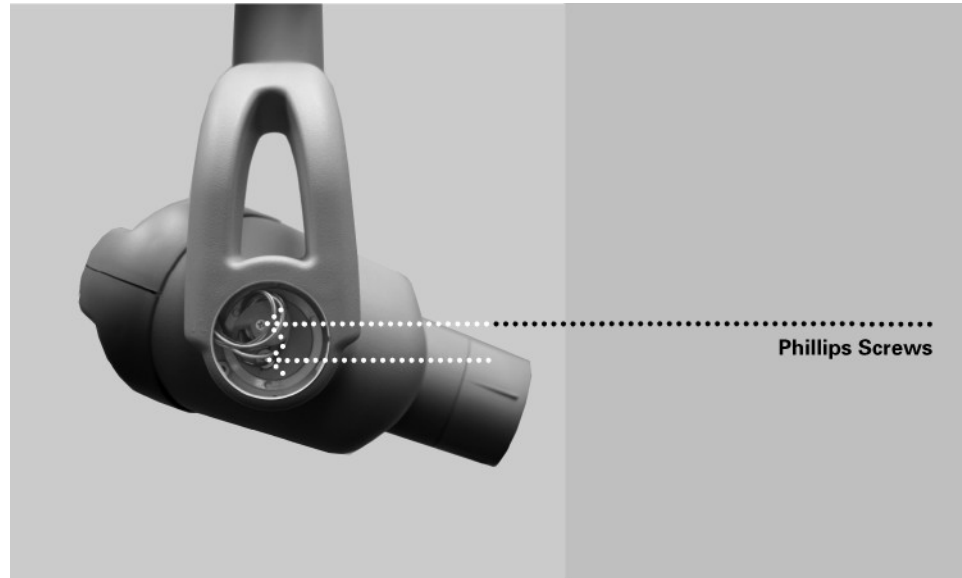
2. Using a small flat-blade screwdriver or pocketknife, pry off the cap on the side of the yoke (see Figure 62).

**Figure 62**  
Plastic Cap



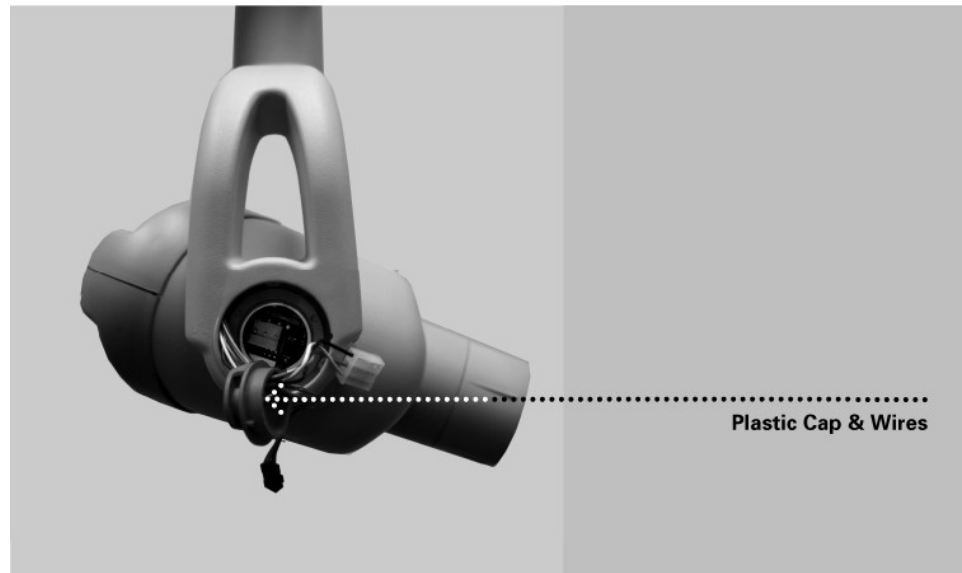
3. Remove the two Phillips screws shown in Figure 63 from the plastic cap holding the wires on the Tubehead.

**Figure 63**  
**Location of Phillips**  
**Screws**



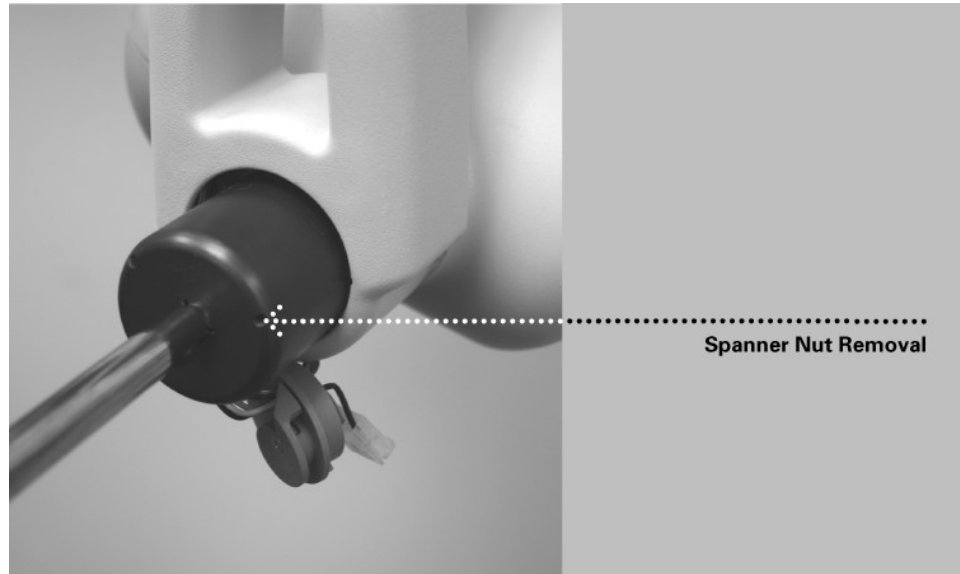
4. Using the needle-nose pliers, remove the plastic cap that the wires are threaded through.
5. Use the needle-nose pliers to gently disconnect the two connectors plugged into the Tubehead and move the wires and plastic cap out of the way.

**Figure 64**  
**Location of Plastic**  
**Cap and Wires**



6. Attach the spanner wrench to your 3/8-inch ratchet and 3/8-inch ratchet extension.
7. Use the spanner wrench to remove the first spanner nut from the Tubehead, as shown in Figure 65.
8. Remove the second spanner nut. Use caution to balance the tube.

**Figure 65**  
**Spanner Nut**  
**Removal**



9. After removing the second spanner nut, gently rotate the Tubehead back and forth, pulling it out of the yoke. After removing the Tubehead, you should have all of the parts in the picture below, including the brown friction ring as shown in Figure 66.
10. Place the brown friction ring in the yoke and properly line it up with the hole before inserting the replacement Tubehead.

**Figure 66**  
**Brown Friction Ring**



The installation procedure for the new Tubehead is the reverse of the Tubehead removal instructions.

## Mechanical Adjustments

### Determining the Necessary Adjustment

The balance and friction of the Articulating Arm and the friction of the Tubehead are set initially at the factory. During the installation process, check the balance and friction. When moving the Tubehead, the Articulating Arm should be steady in all positions and move before the Horizontal Arm.

**Note:** The mechanical adjustments should not be used to compensate for a system that is not properly leveled on the wall.

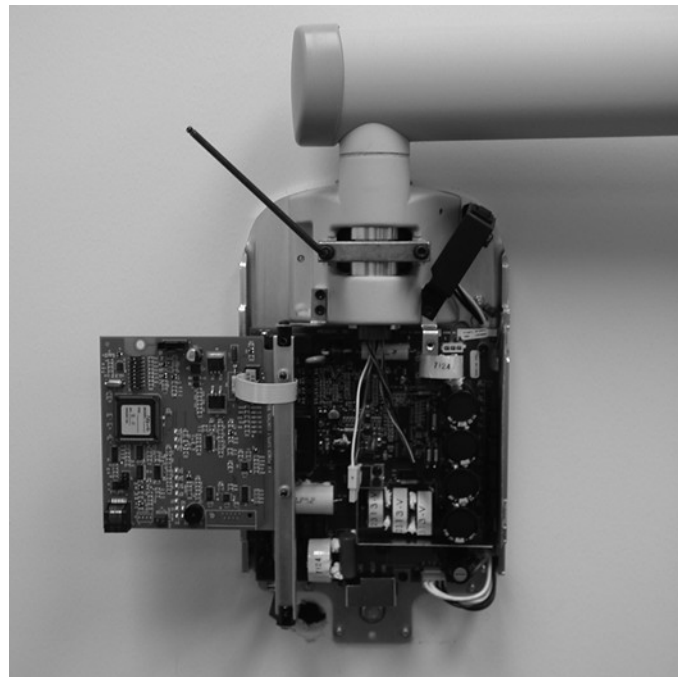
### Tubehead Movement

The movement of the Tubehead is set in the factory and cannot be adjusted.

### Horizontal Arm Adjustment

Note: If performing this adjustment as part of the initial installation of the VetVision DC, omit steps 1-3.

1. Remove the screw from the Control Unit front cover.
2. Carefully remove the front cover.  
**Note:** If the Operator Panel is installed on the Control Unit, carefully keep the Operator Panel together with the front cover.
3. Unplug the cable connectors and set the front cover aside.
4. Locate the brake assembly at the top of the Control Unit. The brake assembly has a screw on either side of a clamping bar over the Horizontal Arm pivot post.
5. Using a 4 mm Allen wrench, as shown in Figure 67, tighten the screws equally to apply adequate braking to the pivot post so that Horizontal Arm begins to move after the Articulating Arm.
6. Replace and re-connect the front cover of the Control Unit. Replace the screw on the front cover.



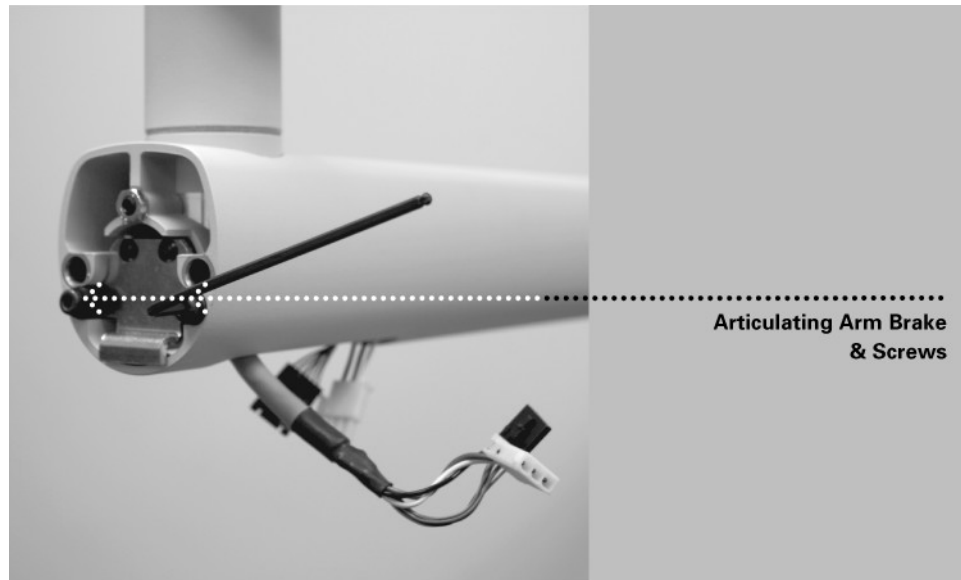
**Figure 67**  
Tightening the Brake



## Adjusting the Horizontal Arm Brake Assembly

Locate the friction assembly screws. Using a 3 mm Allen wrench, as shown in Figure 68, tighten or loosen screws as necessary to get proper movement without unwanted horizontal movement of the Articulating Arm.

**CAUTION!**  
Do not attempt to adjust any other screws in the Horizontal Arm.

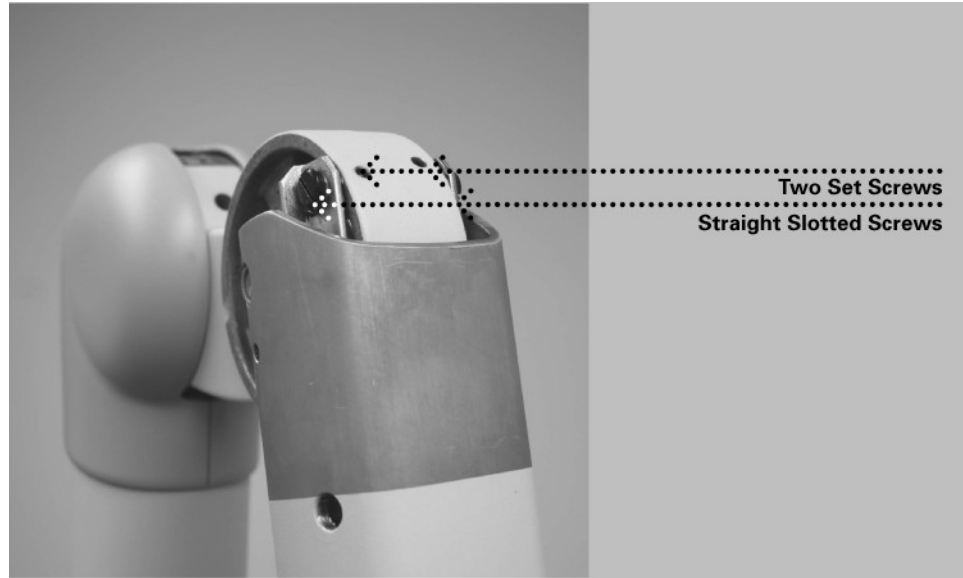


**Figure 68**  
Adjusting the Articulating Arm Brake Assembly

## Adjusting the Articulating Arm

Follow this procedure **ONLY** if the yoke assembly does not stop on its own and hits the horizontal arm. Refer to Figure 69 while following the procedures below.

1. Loosen the two set screws highlighted in Figure 69, but do not remove them completely.
2. Loosen the two straight-slotted screws highlighted in Figure 69 (the figure shows only one of the two screws – the other is located on the opposite side of the arm), but do not remove them completely.
3. Move the articulating arm into the position where you want it to stop before it hits the horizontal arm.
4. Tighten the two straight-slotted screws.
5. Tighten the two set screws.



**Figure 69**  
Adjusting the  
Articulating Arm

### Outside Articulating Arm Vertical Movement

1. Remove the plastic trim covers from the end of the Articulating Arm nearest to the Tubehead.
2. Position the Articulating Arm with the arm nearest the Tubehead fully upward.
3. Insert a 9-inch long 8 mm Allen wrench (T-handle) into the adjustment nut, as shown in Figure 70. Turning the wrench clockwise will cause the Control Unit side of the Articulating Arm to lift. Turning it counterclockwise will cause it to drop.
4. Adjust as necessary until the Control Unit side of the Articulating Arm no longer drifts.
5. Replace the plastic covers on the end of the Articulating Arm.



**Figure 70**  
Adjusting Vertical  
Movement of the  
Articulating Arm

### Control Unit Side of Articulating Arm Balance Adjustment

1. Remove the plastic covers at the top of the Articulating Arm.
2. Position the Articulating Arm at a 45-degree angle.
3. Place a 9-inch long 8 mm Allen wrench (T-handle) into the adjustment nut inside the Articulating Arm, as shown in Figure 71. Turning the wrench clockwise will cause the Control Unit side of the Articulating Arm to lift. Turning it counterclockwise will cause it to drop.
4. Adjust as necessary until the Control Unit side of the Articulating Arm no longer drifts.
5. Replace the plastic covers on top of the Articulating Arm.



**Figure 71**  
Adjusting  
Articulating Arm  
Balance

### Articulating Arm Friction Adjustments

The VetVision DC has four friction adjustment points located at the four pivot points of the Articulating Arm. These friction points can be adjusted to reduce or increase the force needed to position the Articulating Arm.

1. Remove the plastic covers on the Articulating Arm to reveal the adjustment points.
2. Using a 2 mm Allen wrench, as shown in Figure 72, tighten both screws evenly at each adjustment point until the movement of the Articulating Arm is as desired. Do not loosen adjustment points so far as to allow the Articulating Arm to drift.

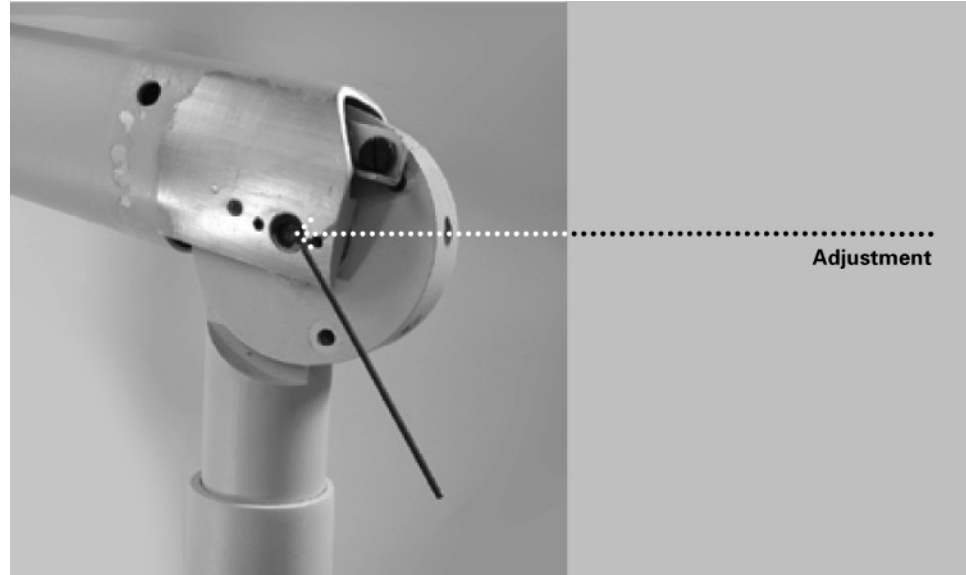







Figure 72  
Friction  
Adjustments

## Pre-programmed Exposure Times

The tables below show the factory default exposure settings for each combination of Tooth, Image Receptor Type, and Patient Size on the Operator Panel. These exposure settings can be modified using the System Configuration mode. See the System Configuration section for details.

8-inch Cone									
Setting		Progeny		Phosphor Plate		D Speed		F Speed	
		Large*	Small*	Large	Small	Large	Small	Large	Small
Upper Canine 	kV	70	65	60	60	60	60	60	60
	mA	6	7	7	7	7	7	7	7
	Seconds	0.100	0.080	0.100	0.064	0.200	0.125	0.080	0.050
Lower Canine 	kV	70	65	60	60	60	60	60	60
	mA	6	7	7	7	7	7	7	7
	Seconds	0.080	0.064	0.125	0.080	0.250	1.160	0.100	0.064
Incisors 	kV	70	65	60	60	60	60	60	60
	mA	6	7	7	7	7	7	7	7
	Seconds	0.080	0.080	0.250	0.125	0.400	0.250	0.160	0.100
Premolars 	kV	70	65	60	60	60	60	60	60
	mA	6	7	7	7	7	7	7	7
	Seconds	0.100	0.080	1.125	0.080	0.250	0.160	0.100	0.064
Molars 	kV	70	65	60	60	60	60	60	60
	mA	6	7	7	7	7	7	7	7
	Seconds	0.125	0.100	1.160	1.100	0.320	0.200	0.125	0.080

# Replacement Parts

## Arm and Tubehead

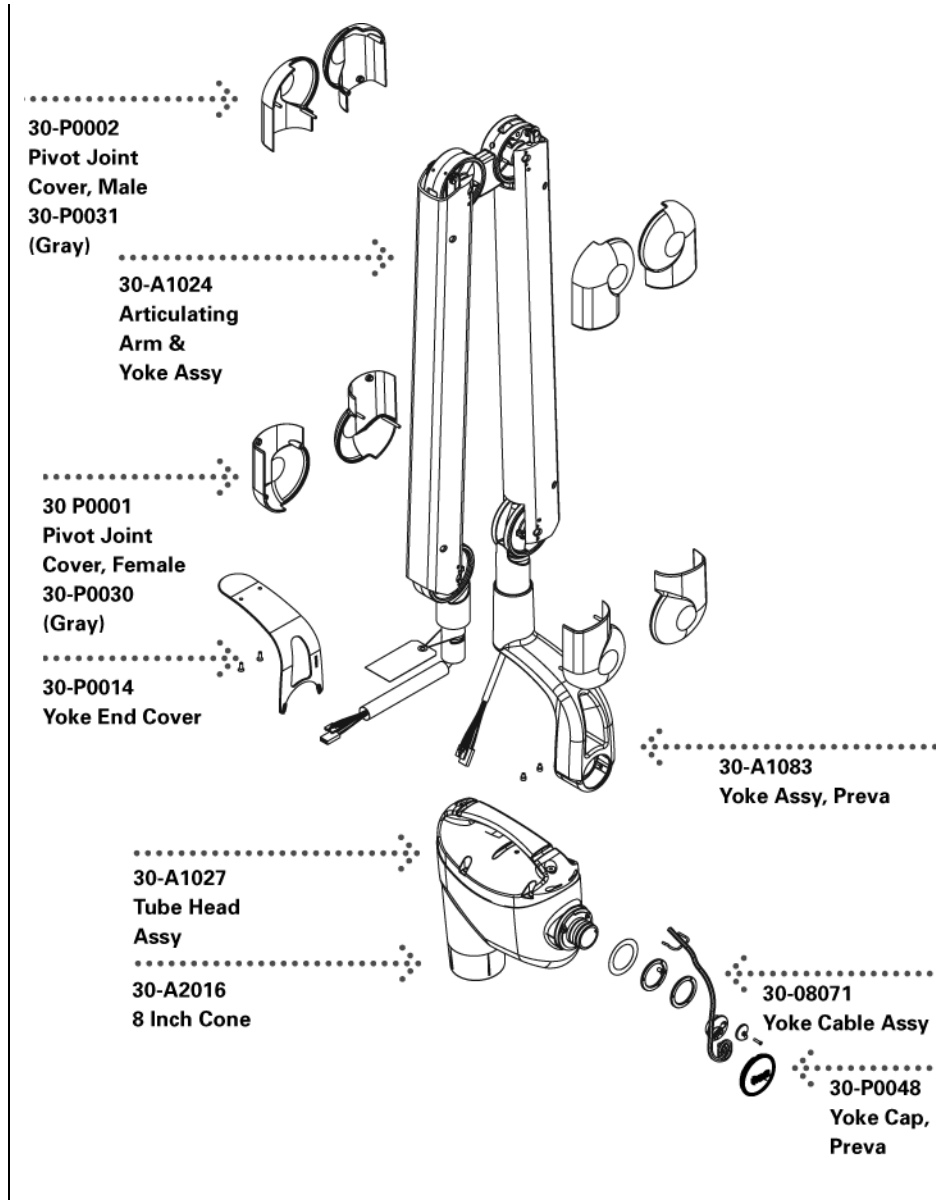


Figure 73  
Arm and  
Tubehead

# Horizontal Arm

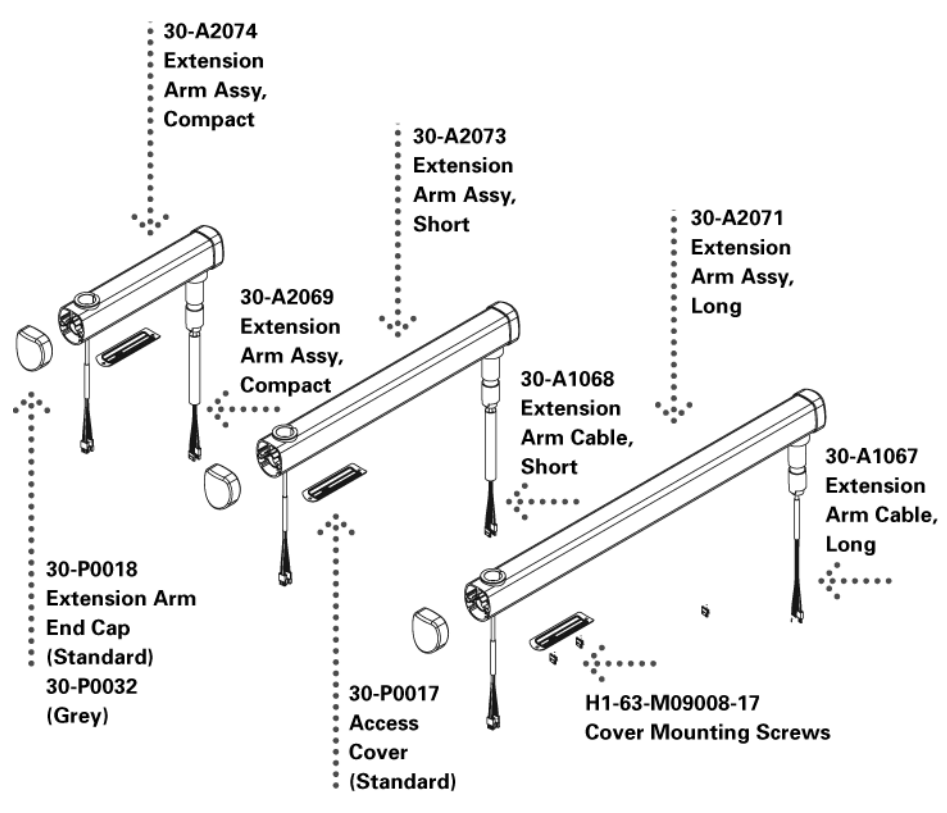


Figure 74  
Horizontal Arm



### Mounting Plates

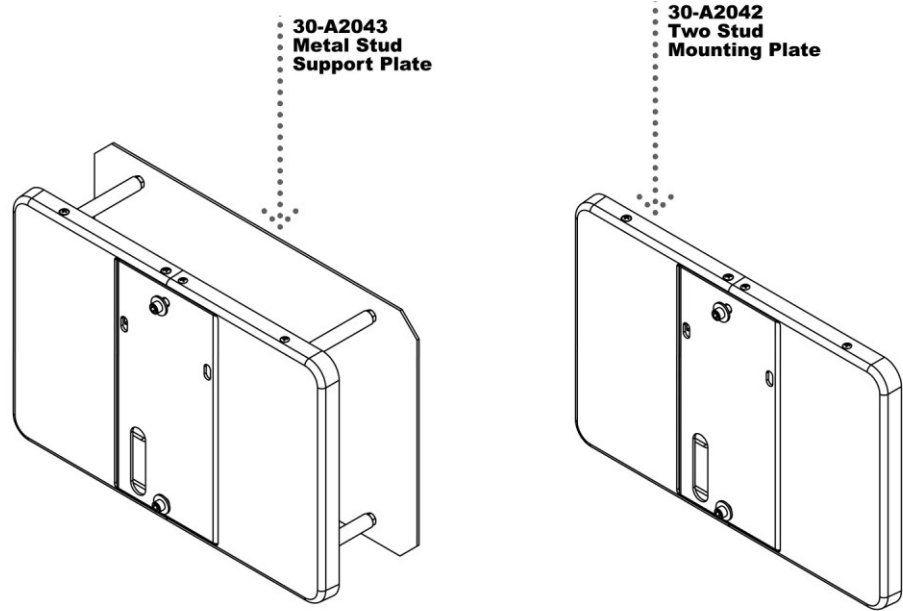


Figure 75  
Mounting Plates

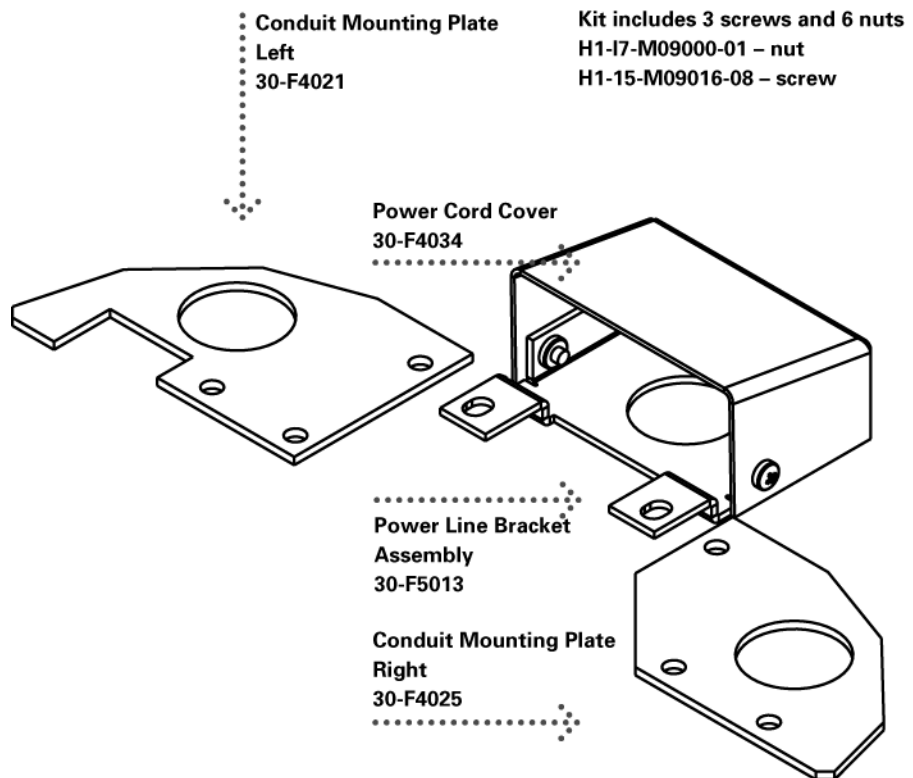


Figure 76  
4x4 Mount Kit  
30-A2099

# Operator Panel

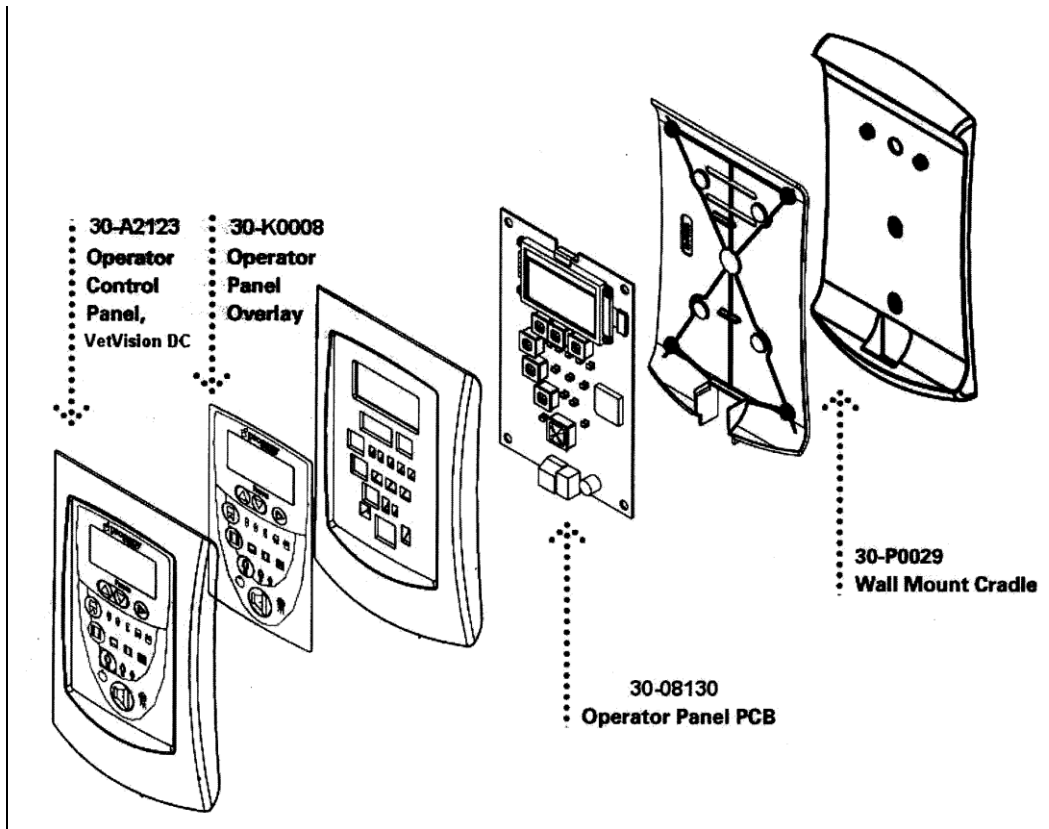
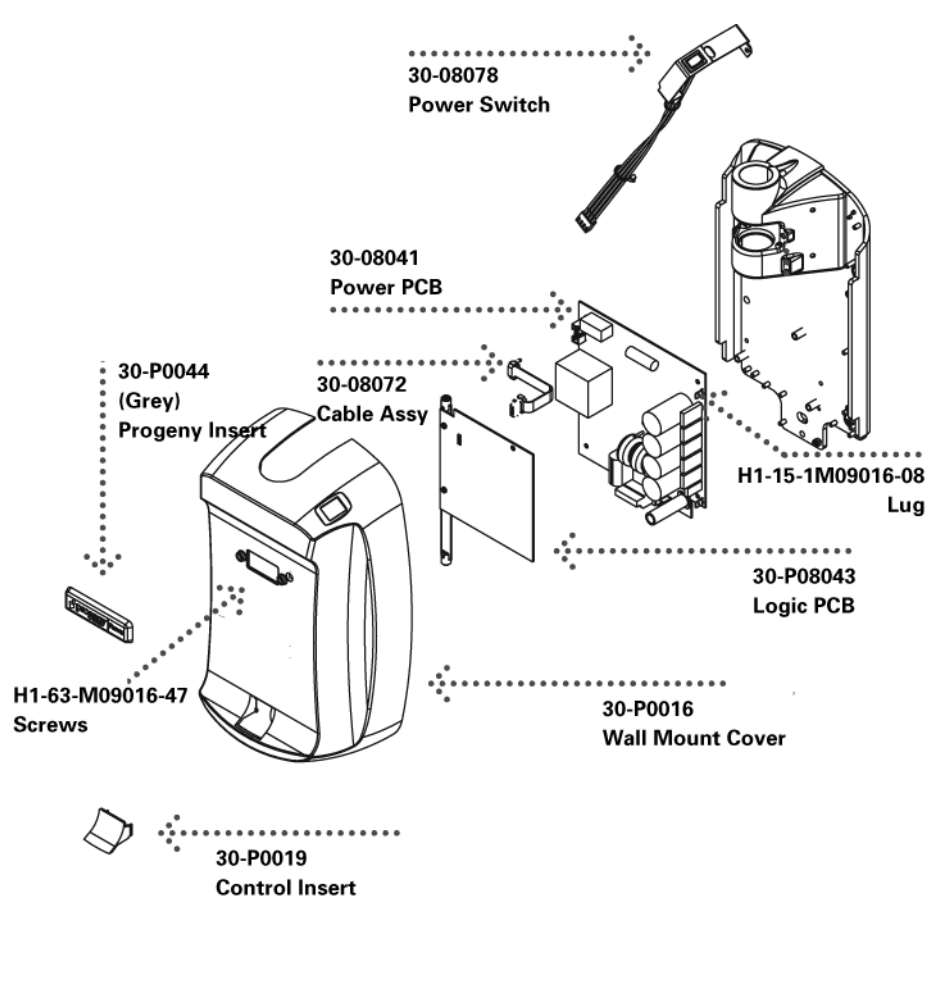


Figure 77  
Operator Panel

### Control Unit



**Figure 78**  
Control Unit  
Assembly

# Hand Switch

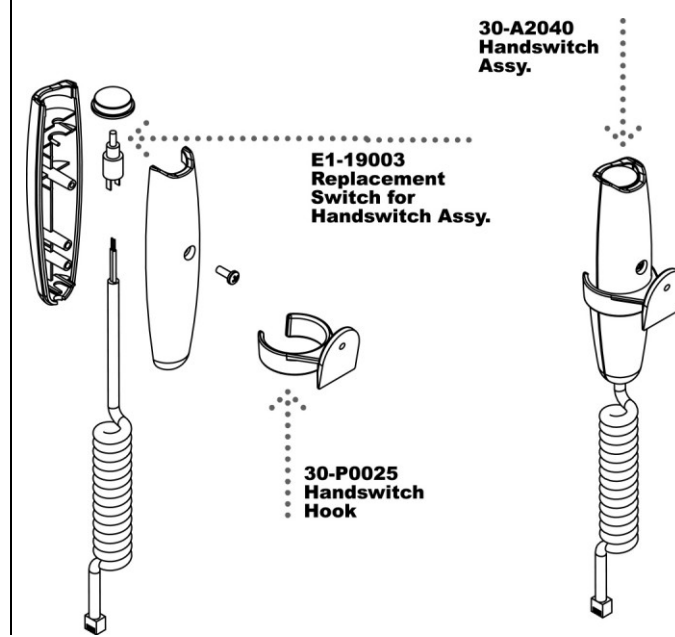


Figure 79  
Hand Switch

## Specifications

### VetVision DC X-Ray System

The following specifications contain information required per 21 CFR to be provided to the user.

<b>Line Voltage</b>	100-230 VAC +/- 10% 50/60 Hz
<b>Line Load</b>	Max. current 5 amps
<b>Maximum Rated Tube Potential</b>	70 KVp
<b>kVp Accuracy</b>	+/- 5% selectable
<b>Tube Current</b>	4-7 mA +/- 1 mA
<b>Exposure Time</b>	10 ms through 2.00 seconds
<b>Timer Accuracy</b>	5% +/- 1 ms
<b>Source to Skin Distance</b>	8 inch (20 cm) 12 inch (30 cm)
<b>Minimum Half Value Layer</b>	1.7 mm Aluminum equivalent at 70 kVp
<b>Minimum Inherent Filtration</b>	2 mm Aluminum equivalent @ 70 kVp
<b>Focal Spot</b>	0.4 mm (IEC 336)
<b>Automatic Cooling Time</b>	15 times the exposure time wait before the next exposure can begin
<b>Leakage Technique Factors</b>	1.5 mA at 70 kVp
<b>Target Angle</b>	12.5 degrees
<b>Operating Temperature</b>	+50 F/+95 F (+10 C/+35 C)
<b>Storage Temperature</b>	-31F/+150 F (-35 C/+66 C)
<b>Maximum Altitude</b>	12,000 ft
<b>Cone Focal Length</b>	8 inch (20 cm) for bisecting angle technique 12 inch (30 cm) for paralleling technique
<b>Diameter of X-Ray</b>	2.72 inches (6.9 cm) at the end of the Cone  Specifications for optional cones differ

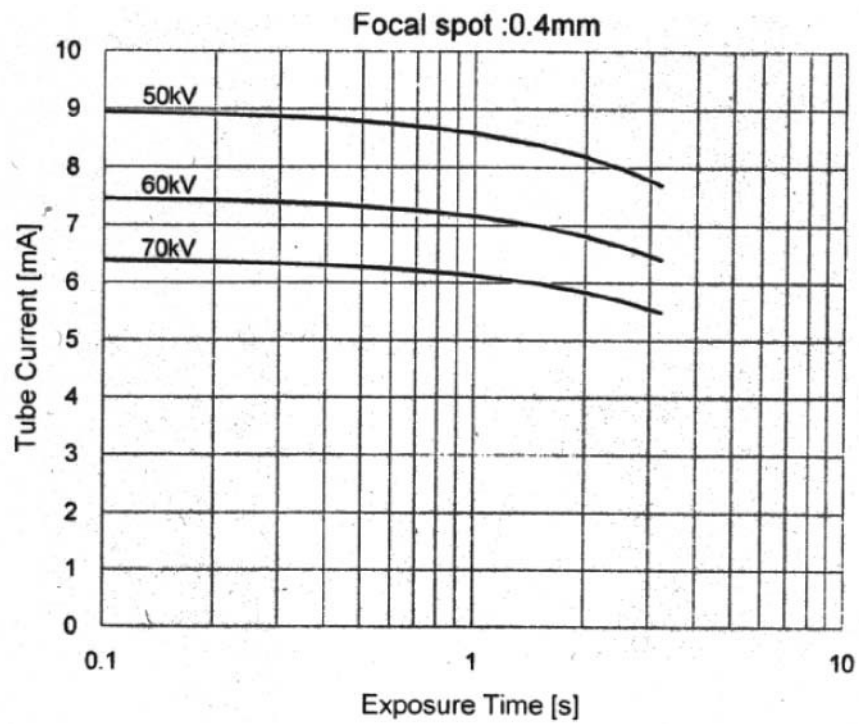
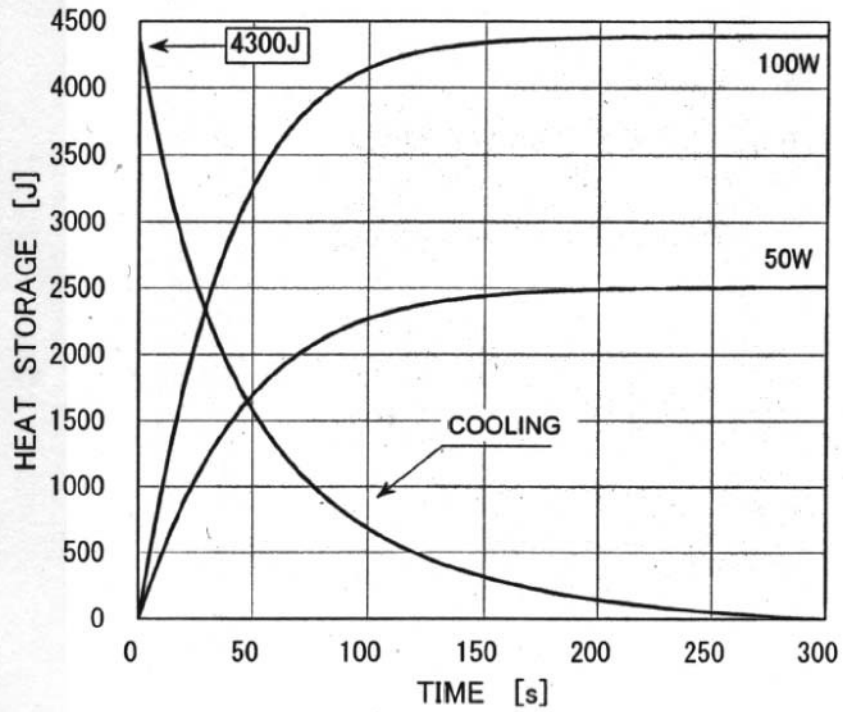
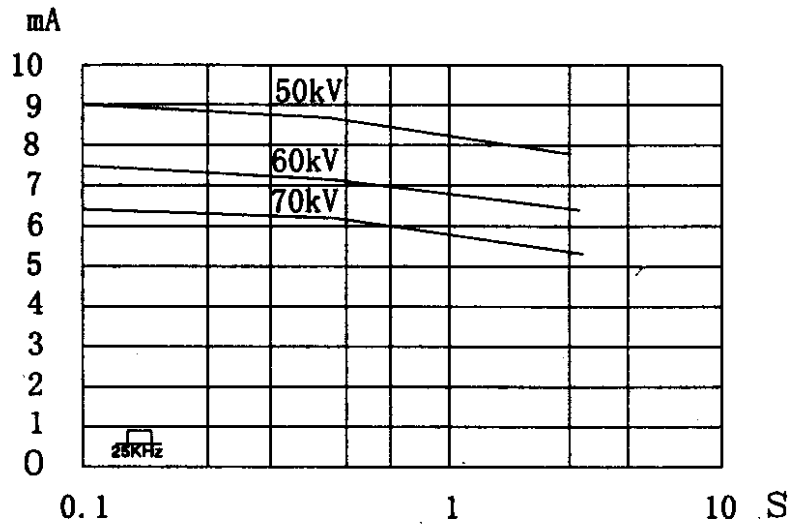
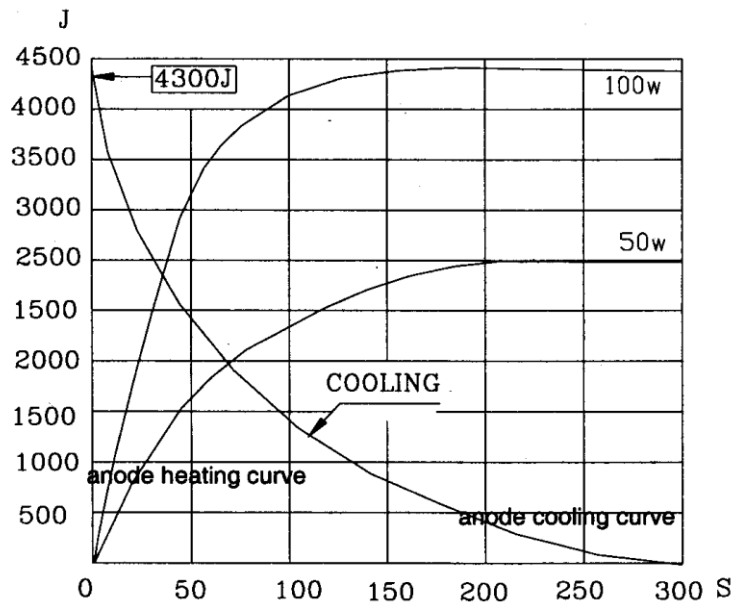


Figure 80  
Toshiba Tube  
Rating Charts



Rating Chart



Thermal Characteristics Chart

Figure 81  
Kailong Tube Rating Charts

## Appendix A

### Assembly Instructions for VetVision DC Mobile Unit

#### Tools Required

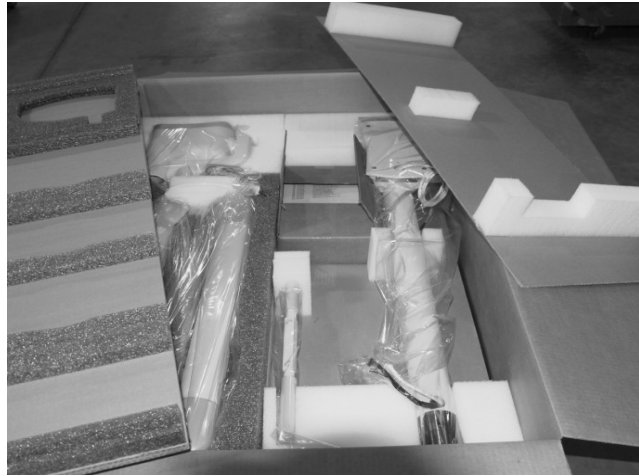
3/8 square drive hex key 10 mm  
3/8 square drive hex key x 6-inch extension  
3/8 square drive ratchet  
No. 1 Phillips screwdriver  
7 mm nut driver  
Small flat-blade screwdriver  
4 mm hex key  
5 mm hex key

**Note:** It is recommended that 2 people assemble the unit.

1. Remove the five screws that hold the control cover. Carefully remove the cover.
2. Install the column into the base with the remote mount facing the control and install the special M12 socket cap screw into the hole under the control mounting plate and tighten.
3. Loosen but **DO NOT REMOVE** the M6 button head screws that hold the bushing assembly into the column so that the arm assembly will not interfere with the screws during installation.
4. Plug the cable to the arm assembly, insert the arm assembly into the bushing, and gently pull the other end of the cable as you install the arm assembly.
5. With the Tubehead over the long legs, tighten the M6 button head screws.
6. Install the remote cradle and remote exposure button with the two M5 X 8 mm Phillips pan head screws. Route the remote cable through the rectangular hole and the remote exposure cable through the slot in the bottom of the cradle.
7. Remove the backing on the remote exposure holder and install the M3 X 12 mm Phillips pan head screw. Install on the back of the remote cradle on the left side and tighten the screw, ensuring the holder is straight.
8. Attach the remote cable to the remote, and install the remote to the cradle.
9. Attach the cable from the arm assembly to J1 on the power board, J4 on the Logic Board, and ground wire to the ground lug.
10. Attach the cable from the remote to J1 on the Logic Board.
11. Route both cables so that they do not interfere with installing the cover.
12. Attach the strain relief bracket diagonally across the studs on the chassis.
13. Route the power cord through the rubber grommet in the cover and through the strain relief bracket. Attach the black wire to L on the power block, the white wire to the N on the power block, and the ground wire to the ground lug. Install the Hayco into the strain relief.
14. Plug in the power switch to the two connectors near the power block.
15. Reinstall the cover with the five M3 X 5 mm Phillips pan head screws and, tighten.
16. Install the Velcro strap around the pivot joint at the column and the loose ends around the pivot joint at the Tubehead.
17. Install handle on upper support bracket of the remote with two M6 X 20 mm socket head cap screws and M6 spring lock washer.

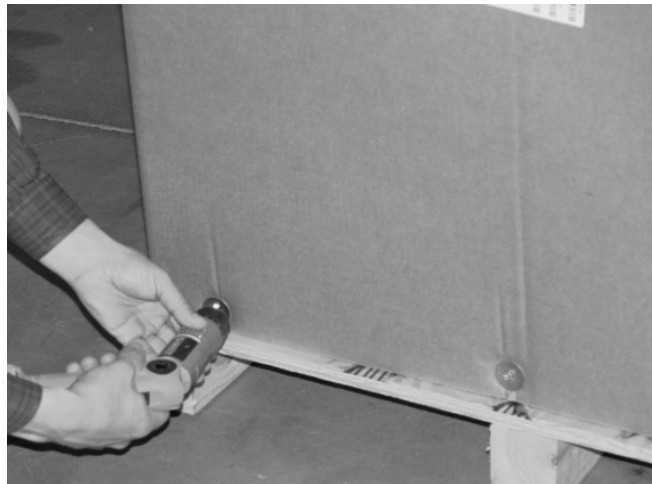


1. Open the box from the top side and remove top layer of packing material (See **Fig 1**)



(FIG 1)

2. Remove **all** transportation screws from the base of the crate ( QTY 10) (See **Fig 2**)



(FIG 2)

3. Lift the shipping box and separate from the crate. There are two layers or parts. Separate the top layer and place on the floor (**This is a two person job**) or remove each piece individually. **NOTE: Take extra care when handling the articulating arm assembly to avoid any damage to tube head.** (See Fig 3)



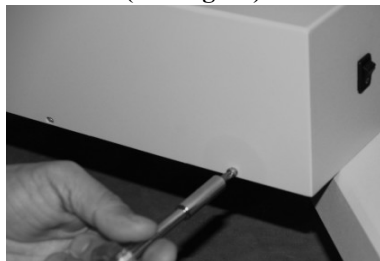
(FIG 3)

4. Cut the transportation band from the lower layer that holds the mobile base. (See fig 4)

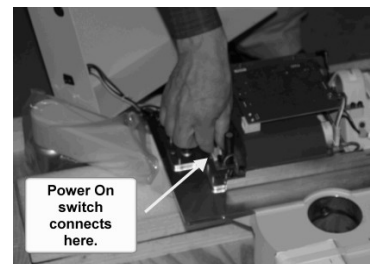


(FIG 4)

5. Remove top cover of control unit by removing screws located at the base of the cover. ( See Fig 5A)  
**NOTE: Be careful when removing top cover. The power switch is connected. Lift carefully and disconnect power switch from the Power Board (See Fig 5B)**

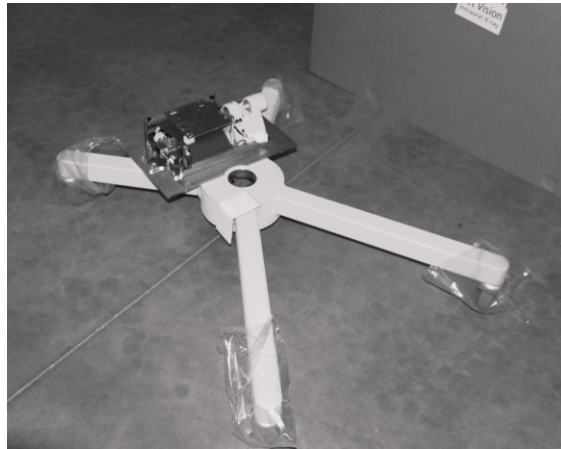


(FIG 5A)



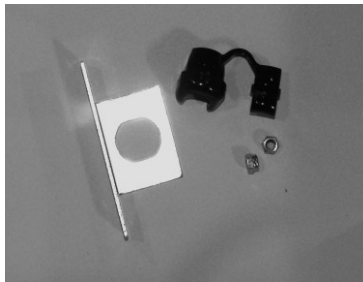
(FIG 5B)

6. Separate the mobile unit base from the pallet. **CAUTION: This should be done taking proper lifting precautions. The base is heavy and requires two people to lift.** (See Fig 6)

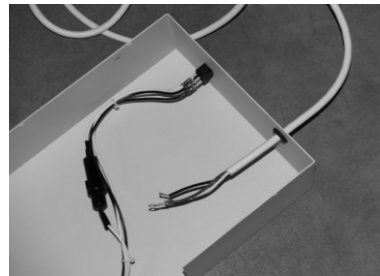


(FIG 6)

7. Locate hardware, clamp and bracket for power cord (See Fig 7A). Feed the power cord through the grommet of the control unit cover. (See Fig 7B). Mount the clamp and bracket to the chassis of control unit. (See Fig 7C)



(FIG 7A)



(FIG 7B)



(FIG 7C)

8. Connect power cord.

8A. Remove EMI shield. (See FIG 8A)

- 8B. Attach to power cord to the Terminal Block as detailed below. (See Fig 8B)

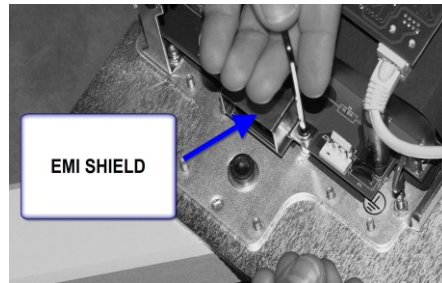
Black ...”Line”

White....”Neutral”

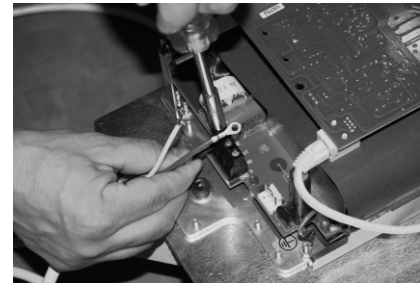
Green....”Ground” (place ground underneath the EMI shield  
.Lock down with Allen screw.)

**NOTE: Take care not to pinch ground wire with EMI**

**Shield.**



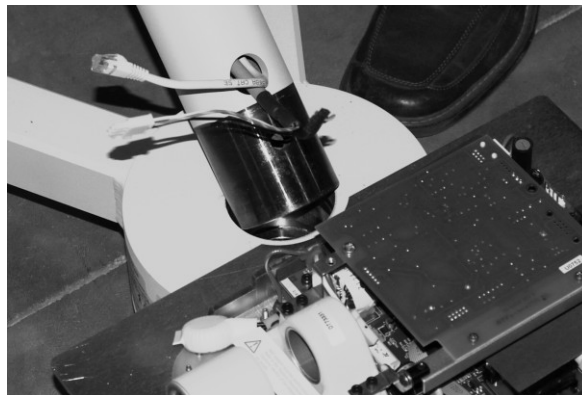
(FIG 8A)



(FIG 8B)

9. Locate the mobile unit post (located in the top layer of parts removed in step 3) and insert into the mobile base as shown in Fig. 9.

**NOTE: Take care not to pinch the Cat 5 cable or the tube head connectors. (See FIG 9)**

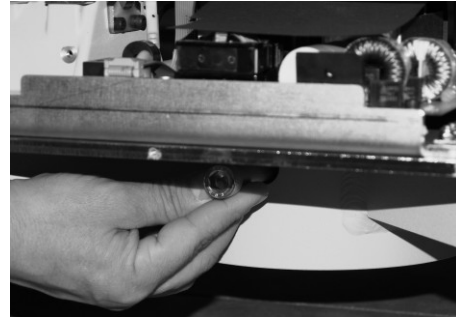


(FIG 9)

10. In the “Kit, Mobile Stand” package (Part #30-A2098) (See **fig 10A**). Locate and insert the bolt used to secure the post to the mobile base.(Requires 10mm Allen wrench) (See **Fig 10B**)



(FIG 10A)



(FIG 10B)

11. Back out the Allen bolts used to secure the articulated arm to the post. (QTY 2). This allows the articulating arm to be inserted completely into post. (See **Fig 12**)



(Fig 12)

12. Locate the Articulated Arm/Tube head assembly .Remove the red transportation label. Pull back the plastic packaging to expose shaft and remove paper tube protecting cables and connectors.

13. Lift the arm/tube head carefully and guide the cables through the top off the post. Carefully insert the articulated arm and take care not to pinch or damage the connectors. (See Fig 13)



(FIG 13)

14. Secure the articulated arm assembly to the post with the two Allen bolts that were backed out in step 11. ( See Fig 14)



(FIG 14)

15. Locate and install the articulating arm brake assembly. (See Fig 15A). Install and adjust by tightening to the point where the articulating arm does not drift when you lightly push the arm. (See Fig 15B)



(FIG 15A)



(FIG 15B)

16. Connect the power and feedback cables (See Fig 16A). Insert cables into the post. (See Fig 16B)

**NOTE: If needed pull excess into the control box.**



(FIG 16 A)



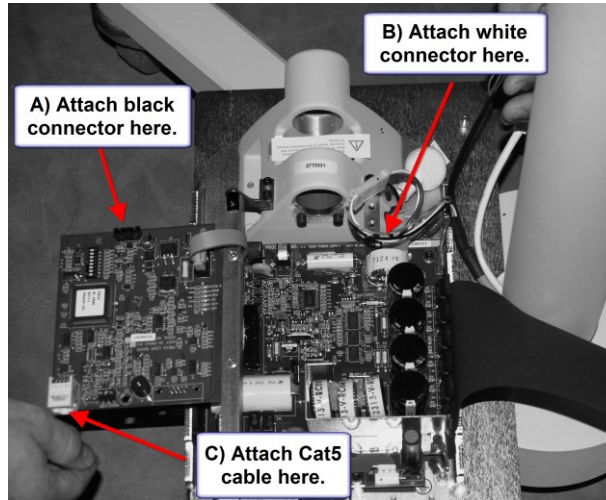
(FIG 16 B)

17. Install the cover plate. (See Fig 17)



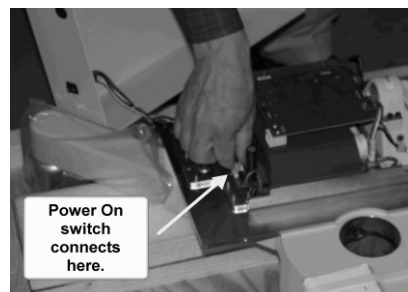
(FIG 17)

18. Remove the screw that locks down the Logic board. Swing out the Logic Board and connect the three connections as shown below. ( See Fig 18)
- 18A) Black connector (Feedback from tube head)
  - 18B) White connector (Power to tube head)
  - 18C) Cat5 (network cable)

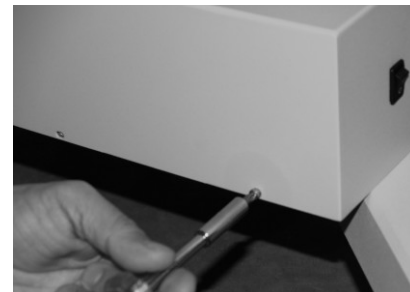


(FIG 18)

19. Connect the “Power on Switch” connector to the Power Supply Board. (See Fig 20A). Attach the control unit cover. (See Fig 20B)



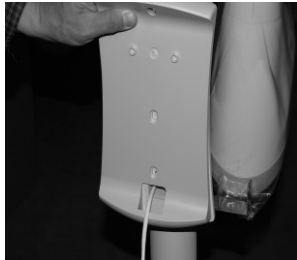
(FIG 20A)



(FIG 20B)



20. Feed the Cat5 cable through the Operators panel cradle. (See Fig 21A) Feed remote exposure cable through the bottom of cradle. **NOTE: Allow a few coils of slack inside for strain relief.** (See Fig 21B). Attach the cradle with supplied hardware ( See Fig 21C)



(FIG 21A)

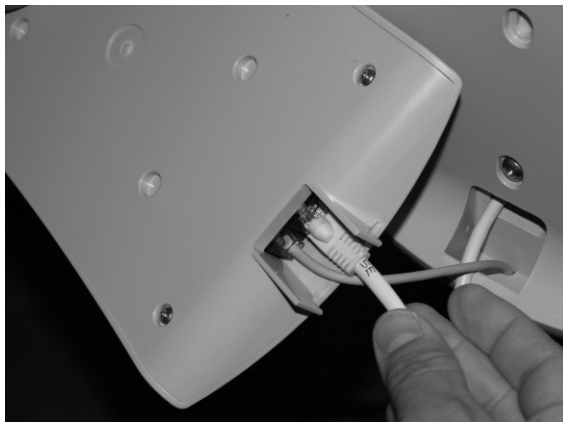


(FIG 21B)



(FIG 21C)

21. Connect Cat5 cable and remote switch cable to the Operators Panel. (See Fig 22) Mount the Operators Panel into cradle.



(FIG 22)

22. Install the mobile unit handle with the supplied hardware. (See Fig 23)

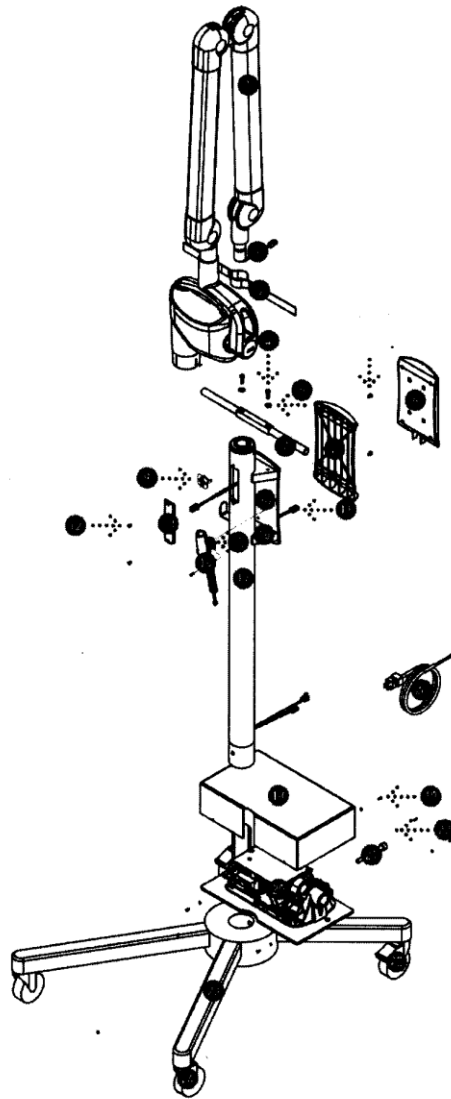


(FIG 23)

23. Attach the remote switch holster by removing the adhesive backer and attaching to the frame. (See Fig 24)



(FIG 24)



Part and Part Numbers, Preve Mobile Unit

1	30-A1024	Articulated Arm & Tube Head
2	E1-13029	8 Cond. RJ45 to RJ45 2 m.
3	30-A2093	Velcro Strap
4	H1-15-M16020-10	Screw
5	H1-61-M13008-01	Screw
6	30-A2123	Operator Panel
7	30-A2111	Mobile Stand Handle with Grips
8	30-M3010	Cradle
9	30-A2109	Brake
10	30-M0048	Mounting Plate Remote
11	E1-13029	8 Cond. RJ45 to RJ45 2 m.
12	H1-63-M09008-17	Screw
13	30-P0017	Access Cover
14	30-A2040	Remote Control Switch Assy.
15	H1-61-M05012-01	Screw
16	30-M0047	Mounting Bracket
17	30-M0045	Column
18	30-08098	Switch Assm., Preve Mobil Stand
19	H1-61-M05008-01	Screw
20	30-A1032	Control
21	30-M0046	Column Screw
22	H1-P2-M04000-01	Screw
23	30-A2078	Mobile Stand Base
24	30-50035	Caster, Swivel
25	30-50036	Caster, Swivel w/ Brake
26	E1-13028	Line Cord

Figure 81  
Mobile Unit  
Assembly

# Appendix B

## Electronics Block Diagram

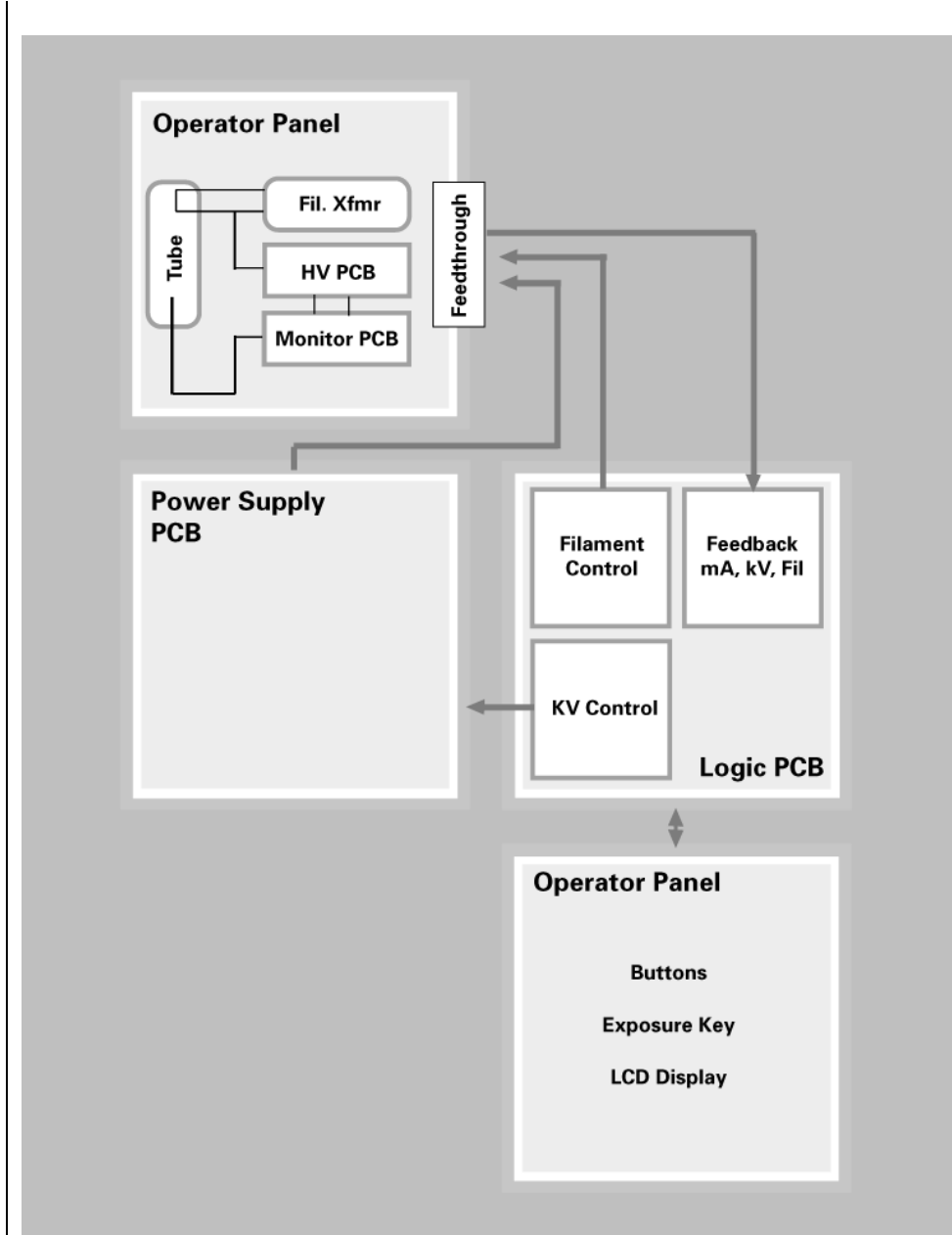


Figure 82  
Electronic Block  
Diagram